



# **FOOD ESTABLISHMENT PLAN REVIEW GUIDELINE**

Prepared By: Northeast Region  
Plan Review Development Committee  
for the Conference for Food Protection

## **ACKNOWLEDGEMENTS**

The following individuals and/or organizations are to be recognized for their invaluable contributions to the development of this Plan Review Guide:

Federal:

- John P. Schrade, U.S. Food and Drug Administration, Northeast Region, Director of State Programs.
- Karen Coscarelli-Allmond, U.S. Food & Drug Administration, Office of Regulatory Affairs, Division of Human Resource Development.

State:

- Frederick (Rick) Petersen, Stamford, Connecticut Department of Health.
- Northeast Region Plan Review Development Committee.
- South Carolina Department of Health & Environmental Control.
- Todd Stephens, South Carolina Department of Health & Environmental Control.
- Roger Fortman, North Carolina Dept of Health, Food, Lodging and Institutional Sanitation Branch.

Other:

- Conference for Food Protection Plan Review Committee.
- D.L. Lancaster, Consultant, Ann Arbor, Michigan.

## **TABLE OF CONTENTS**

**INTRODUCTION - (pg.iv-xiii)**

**SECTION I. OPERATOR S APPLICATION  
DOCUMENTS - (pg. 1-20)**

**SECTION II. REGULATORY  
AUTHORITY COMPLIANCE  
REVIEW LIST - (pg. 21-25)**

**SECTION III. FOOD ESTABLISHMENT  
GUIDE FOR DESIGN,  
INSTALLATION, & CONSTRUCTION  
RECOMMENDATIONS - (pg. 26-136)**

**SECTION IV. PLAN REVIEW OUTLINE  
OF APPLICABLE 1999  
FOOD CODE SECTIONS - (pg. 137-140)**

**2000**

## **INTRODUCTION**

This food establishment Plan Review document has been developed for the purpose of assisting both regulatory and industry personnel in achieving greater uniformity in the plan review process.

Plan review of food service establishments, retail food stores, and all other food operations, must be maintained as a high priority by all regulatory food agencies for both new and existing facilities.

This document has been developed to serve as a guide in facilitating greater uniformity and ease in conducting plan review whether your position is a regulator or an industry person wishing to build or to expand. You need not be an expert to effectively complete this process.

A good review of plans helps to avoid future problems. By listing and locating equipment on floor plans and diagramming specifications for electrical, mechanical and plumbing systems, potential problems can be spotted while still on paper and modifications made BEFORE costly purchases, installation and construction.

Food establishment plan review is recognized as an important food program component that allows:

- Regulatory agencies to ensure that food establishments are built or renovated according to current regulations or rules.
- Industry to establish an organized and efficient flow of food.
- Regulatory agencies to eliminate code violations prior to construction.

The 1999 Food Code (which contains the recommendations of the United States Public Health Service, FDA and consists of model requirements for safeguarding public health and ensuring food is unadulterated and honestly presented when offered for sale to the consumer), is used as a reference in completing this guide.

### **Questions to Consider:**

1. \*Will the menu offer food that requires extensive preparation (washing, cutting, mixing, etc.)?

The number and placement of hand sinks becomes more important with more complex food preparation. A culinary sink is needed for washing fruits and vegetables and for other preparation.

2. \*What hours will the food service be open?... lunch and dinner?... 24 hours per day?

Increased equipment capacity and storage space should be considered for establishments with extended hours of operation. Highly durable floor, wall and ceiling finishes should be considered.

3. \*How much food will be cooked and immediately served, or prepared in advance for later service?

Preparing food in advance requires more refrigeration space for thawing foods, cooling hot foods, and storing of cold foods.

4. \*How often will supplies be delivered?

The delivery frequency is important in determining the amount of refrigerated, frozen and dry food storage space.

5. \*What is the maximum number of employees working on one shift?

The number of employees is necessary to determine work/aisle space and the number of lockers to provide.

6. \*Have you or any of your employees been trained in food safety or Hazard Analysis Critical Control Point (HACCP) concepts?

Training in both food safety principles and HACCP principles provides you and your employees with insight into the numerous hazards encountered in a food establishment.

**Specific Instructions to Applicants:**

1. Fill out Section I.
2. Provide blueprints & equipment specification sheets.
3. Include proposed menu.
4. Provide site plan.
5. Keep copy for personal records.
6. Submit to Regulatory Authority for review.

# PLAN REVIEW PROCESS FLOW CHART

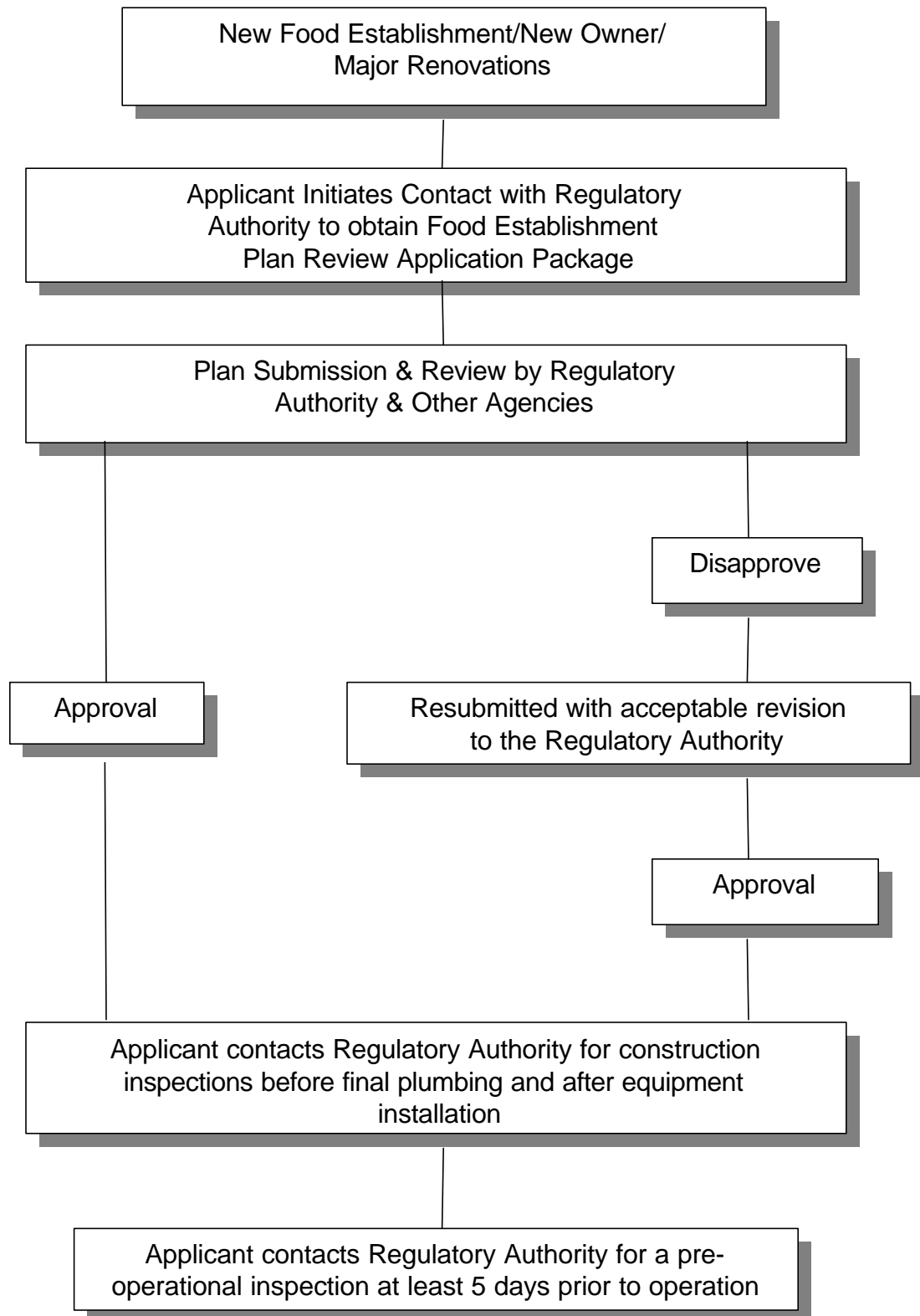

## FOOD ESTABLISHMENT PLAN REVIEW GUIDE

### *DEFINITIONS*

**“Acceptable food equipment”** means food equipment that is deemed to be in conformance with Food Code provisions such as equipment that is certified or classified for sanitation by an American National Standards Institute (ANSI)-accredited certification program. Such equipment is deemed to comply with Parts 4-1 and 4-2 of the Food Code.

Under ANSI document CA-1 ANSI Policy and Criteria for Accreditation of Certification Programs, it has been stipulated that:

“For food equipment programs, standards that establish sanitation requirements shall be specified government standards or standards that have been ratified by a public health approval step. ANSI shall verify that this requirement has been met by communicating with appropriate standards developing organizations and governmental public health bodies.”

The term “certified” is used when an item of food equipment has been evaluated against an organization’s own standard. The term “classified” is used when one organization evaluates an item of food equipment against a standard developed by another organization.

**“Air Break”** means a piping arrangement in which a drain from a fixture, appliance, or device discharges indirectly into another fixture, receptacle or interception at a point below the flood level rim. The connection does not provide an unobstructed vertical distance and is not solidly connected but precludes the possibility of backflow to a potable water source

**“Air Gap”** means the unobstructed vertical distance through the free atmosphere between the lowest opening from any pipe or outlet supplying fixture, or other device, and the flood level rim of the receptacle. The vertical physical separation shall be at least two times the inside diameter of the water inlet pipe above the flood rim level but shall not be less than one inch.

**Approved** means acceptable to the regulatory authority based on a determination of conformity with principles, practices, and generally recognized standards that protect public health.

**Backflow** means the flow of water or other liquids, mixtures, or substances into the distributing pipes of a potable supply of water from any source or sources other than its intended source. Back-siphonage is one type of backflow.

**Backflow Preventer** means a device or means to prevent backflow.

**Back-siphonage** means the flowing back of used, contaminated, or polluted water from a plumbing fixture or vessel or other sources into a potable water supply pipe due to a negative

pressure in such pipe.

**Corrosion-resistant material** means free of cracks or other openings that allow the entry or passage of moisture.

**Easily Disassembled Equipment** means equipment that is accessible for cleaning and inspection by:

- (a) Disassembling without the use of tools, or
- (b) Disassembling with the use of handheld tools commonly available to maintenance and cleaning personnel such as screwdrivers, pliers, open-end wrenches, and Allen wrenches.

**Easily Movable** means:

- (a) Weighing 14 kg (30 pounds) or less; mounted on casters, gliders, or rollers; or provided with a mechanical means requiring no more than 14 kg (30 pounds) of force to safely tilt a unit of equipment for cleaning; and
- (b) Having no utility connection, a utility connection that disconnects quickly, or a flexible utility connection line of sufficient length to allow the equipment to be moved for cleaning of the equipment and adjacent area.

## **Equipment**

(a) "**Equipment**" means an article that is used in the operation of a food establishment such as a freezer, grinder, hood, ice maker, meat block, mixer, oven, reach-in refrigerator, scale, sink, slicer, stove, table, temperature measuring device for ambient air, vending machine, or warewashing machine.

(b) "**Equipment**" does not include items used for handling or storing large quantities of packaged foods that are received from a supplier in a cased or overwrapped lot, such as hand trucks, forklifts, dollies, pallets, racks, and skids.

Facility See **Physical facilities**

**Food Employee** means an individual working with unpackaged food, food equipment or utensils, or food-contact surfaces

## **Food Establishment**

(a) "**Food establishment**" means an operation that stores, prepares, packages, serves, vends, or otherwise provides food for human consumption:

(I) Such as a restaurant; satellite or catered feeding location; catering operation if the operation provides food directly to a consumer or to a conveyance used to transport people; market; vending location; conveyance used to transport people; institution; or food bank; and

(ii) That relinquishes possession of food to a consumer directly, or indirectly through a delivery service such as home delivery of grocery orders or restaurant takeout orders, or delivery service that is provided by common carriers.

(b) **"Food establishment"** includes:

(i) An element of the operation such as a transportation vehicle or a central preparation facility that supplies a vending location or satellite feeding location *unless the vending or feeding location is permitted by the regulatory authority*; and

(ii) An operation that is conducted in a mobile, stationary, temporary, or permanent facility or location; where consumption is on or off the premises; and regardless of whether there is a charge for the food.

(c) **"Food establishment"** does not include:

(i) *An establishment that offers only prepackaged foods that are not potentially hazardous;*

(ii) *A produce stand that only offers whole, uncut fresh fruits and vegetables;*

(iii) *A food processing plant;*

(iv) *A kitchen in a private home if only food that is not potentially hazardous is prepared for sale or service at a function such as a religious or charitable organization's bake sale if allowed by law and if the consumer is informed by a clearly visible placard at the sales or service location that the food is prepared in a kitchen that is not subject to regulation and inspection by the regulatory authority;*

(v) *An area where food that is prepared as specified in Subparagraph (c)(iv) of this definition is sold or offered for human consumption;*

(vi) *A kitchen in a private home, such as a small family day-care provider; or a bed-and-breakfast operation that prepares and offers food to guests if the home is owner occupied, the number of available guest bedrooms does not exceed 6, breakfast is the only meal offered, the number of guests served does not exceed 18, and the consumer is informed by statements contained in published advertisements, mailed brochures, and placards posted at the registration area*

*that the food is prepared in a kitchen that is not regulated and inspected by the regulatory authority; or*

*(vii) A private home that receives catered or home-delivered food.*

**HACCP Plan** means a written document that delineates the formal procedures for following the Hazard Analysis Critical Control Point principles developed by The National Advisory Committee on Microbiological Criteria for Foods.

**Highly susceptible population** means a group of persons who are more likely than other populations to experience foodborne disease because they are immunocompromised or older adults and in a facility that provides health care or assisted living services, such as a hospital or nursing home; or preschool age children in a facility that provides custodial care, such as a day care center.

**Linens** means fabric items such as cloth hampers, cloth napkins, table cloths, wiping cloths, and work garments including cloth gloves.

**Physical facilities** means the structure and interior surfaces of a food establishment including accessories such as soap and towel dispensers and attachments such as light fixtures and heating or air conditioning system vents.

**Plumbing fixture** means a receptacle or device that:

(a) Is permanently or temporarily connected to the water distribution system of the premises and demands a supply of water from the system; or

(b) Discharges used water, waste materials, or sewage directly or indirectly to the drainage system of the premises.

**Plumbing system** means the water supply and distribution pipes; plumbing fixtures and traps; soil, waste, and vent pipes; sanitary and storm sewers and building drains, including their respective connections, devices, and appurtenances within the premises; and water-treating equipment.

## Potentially Hazardous Food (PHF)

(a) "**Potentially hazardous food**" means a food that is natural or synthetic and that requires temperature control because it is in a form capable of supporting:

- (i) The rapid and progressive growth of infectious or toxigenic microorganisms;
- (ii) The growth and toxin production of *Clostridium botulinum*; or
- (iii) In raw shell eggs, the growth of *Salmonella enteritidis*.

(b) "**Potentially hazardous food**" includes an animal food (a food of animal origin) that is raw or heat-treated; a food of plant origin that is heat-treated or consists of raw seed sprouts; cut melons; and garlic and oil mixtures that are not acidified or otherwise modified at a food processing plant in a way that results in mixtures that do not support growth as specified under Subparagraph (a) of this definition.

(c) "**Potentially hazardous food**" does not include:

- (i) *An air-cooled hard-boiled egg with shell intact;*
- (ii) *A food with an  $a_w$  value of 0.85 or less;*
- (iii) *A food with a pH level of 4.6 or below when measured at 24°C (75°F);*
- (iv) *A food, in an unopened hermetically sealed container, that is commercially processed to achieve and maintain commercial sterility under conditions of nonrefrigerated storage and distribution; and*
- (v) *A food for which laboratory evidence demonstrates that the rapid and progressive growth of infectious or toxigenic microorganisms or the growth of *S. enteritidis* in eggs or *C. botulinum* can not occur, such as a food that has an  $a_w$  and a pH that are above the levels specified under Subparagraphs (c)(ii) and (iii) of this definition and that may contain a preservative, other barrier to the growth of microorganisms, or a combination of barriers that inhibit the growth of microorganisms.*
- (vi) *A food that may contain an infectious or toxigenic microorganism or chemical or physical contaminant at a level sufficient to cause illness, but that does not support the growth of microorganisms as specified under Subparagraph (a) of this definition.*

**Premises** means:

(a) The physical facility, its contents, and the contiguous land or property under the control of the permit holder; or

(b) The physical facility, its contents, and the land or property not described under Subparagraph (a) of this definition if its facilities and contents are under the control of the permit holder and may impact food establishment personnel, facilities, or operations, if a food establishment is only one component of a larger operation such as a health care facility, hotel, motel, school, recreational camp, or prison.

**Refuse** means solid waste not carried by water through the sewage system.

**Regulatory Authority** means the local, state, or federal enforcement body or authorized representative having jurisdiction over the food establishment.

**Safe material** means:

(a) An article manufactured from or composed of materials that may not reasonably be expected to result, directly or indirectly, in their becoming a component or otherwise affecting the characteristics of any food;

(b) An additive that is used as specified in 409 or 706 of the Federal Food, Drug, and Cosmetic Act; or

(c) Other materials that are not additives and that are used in conformity with applicable regulations of the Food and Drug Administration.

**Sealed** means free of cracks or other openings that allow the entry or passage of moisture.

**Sewage** means liquid waste containing animal or vegetable matter in suspension or solution and may include liquids containing chemicals in solution.

**Smooth** means:

(a) A food-contact surface having a surface free of pits and inclusions with a cleanability equal to or exceeding that of (100 grit) number 3 stainless steel;

(b) A nonfood-contact surface of equipment having a surface equal to that of commercial grade hot-rolled steel free of visible scale; and

(c) A floor, wall, or ceiling having an even or level surface with no roughness or projections that render it difficult to clean.

**“Vacuum Breaker** See **Backflow Preventer**

## ***SECTION I***

***FOOD ESTABLISHMENT PLAN REVIEW  
APPLICATION TO BE  
COMPLETED BY THE OPERATOR  
AND SUBMITTED TO THE  
REGULATORY AUTHORITY***

\_\_\_\_\_Regulatory Authority

\_\_\_\_\_

Date:\_\_\_\_\_

FOOD ESTABLISHMENT PLAN REVIEW APPLICATION

\_\_\_\_NEW

\_\_\_\_REMODEL

\_\_\_\_CONVERSION

Name of Establishment:\_\_\_\_\_

Category: Restaurant\_\_\_\_, Institution\_\_\_\_, Daycare\_\_\_\_, Retail Market\_\_\_\_,  
Other\_\_\_\_\_.

Address:\_\_\_\_\_

Phone if available:\_\_\_\_\_

Name of Owner:\_\_\_\_\_

Mailing Address:\_\_\_\_\_

Telephone:\_\_\_\_\_

Applicant's Name:\_\_\_\_\_

Title (owner, manager, architect, etc.):\_\_\_\_\_

Mailing Address:\_\_\_\_\_

Telephone:\_\_\_\_\_

I have submitted plans/applications to the following authorities on the following dates:

\_\_\_\_\_ Governing Board of Council

\_\_\_\_\_Plumbing

\_\_\_\_\_Zoning

\_\_\_\_\_Electric

\_\_\_\_\_Planning

\_\_\_\_\_Police

\_\_\_\_\_Building

\_\_\_\_\_Fire

\_\_\_\_\_ Conservation

\_\_\_\_\_ Other ( )

Hours of Operation: Sun \_\_\_\_\_ Thurs \_\_\_\_\_  
 Mon \_\_\_\_\_ Fri \_\_\_\_\_  
 Tues \_\_\_\_\_ Sat \_\_\_\_\_  
 Wed \_\_\_\_\_

Number of Seats: \_\_\_\_\_

Number of Staff: \_\_\_\_\_  
(Maximum per shift)

Total Square Feet of Facility: \_\_\_\_\_

Number of Floors on which  
operations are conducted \_\_\_\_\_

Maximum Meals to be Served: Breakfast \_\_\_\_\_  
 (approximate number) Lunch \_\_\_\_\_  
 Dinner \_\_\_\_\_

Projected Date for Start of Project: \_\_\_\_\_

Projected Date for Completion of Project: \_\_\_\_\_

Type of Service: Sit Down Meals \_\_\_\_\_  
 (check all that apply) Take Out \_\_\_\_\_  
 Caterer \_\_\_\_\_  
 Mobile Vendor \_\_\_\_\_  
 Other \_\_\_\_\_

Please enclose the following documents:

\_\_\_\_\_ Proposed Menu (including seasonal, off-site and banquet menus)

\_\_\_\_\_ Manufacturer Specification sheets for each piece of equipment shown on the plan

\_\_\_\_\_ Site plan showing location of business in building; location of building on site including alleys, streets; and location of any outside equipment (dumpsters, well, septic system - if applicable)

\_\_\_\_\_ Plan drawn to scale of food establishment showing location of equipment, plumbing, electrical services and mechanical ventilation

\_\_\_\_\_ Equipment schedule

### **CONTENTS AND FORMAT OF PLANS AND SPECIFICATIONS**

1. Provide plans that are a minimum of 11 x 14 inches in size including the layout of the floor plan accurately drawn to a minimum scale of 1/4 inch = 1 foot. This is to allow for ease in reading plans.
2. Include: proposed menu, seating capacity, and projected daily meal volume for food service operations.
3. Show the location and when requested, elevated drawings of all food equipment. Each piece of equipment must be clearly labeled on the plan with its common name. Submit drawings of self-service hot and cold holding units with sneeze guards.
4. Designate clearly on the plan equipment for adequate rapid cooling, including ice baths and refrigeration, and for hot-holding potentially hazardous foods.
5. Label and locate separate food preparation sinks when the menu dictates to preclude contamination and cross-contamination of raw and ready-to-eat foods.
6. Clearly designate adequate handwashing lavatories for each toilet fixture and in the immediate area of food preparation.
7. Provide the room size, aisle space, space between and behind equipment and the placement of the equipment on the floor plan.
8. On the plan represent auxiliary areas such as storage rooms, garbage rooms, toilets, basements and/or cellars used for storage or food preparation. Show all features of these rooms as required by this guidance manual.
9. Include and provide specifications for:
  - a. Entrances, exits, loading/unloading areas and docks;
  - b. Complete finish schedules for each room including floors, walls, ceilings and coved juncture bases;
  - c. Plumbing schedule including location of floor drains, floor sinks, water supply lines, overhead waste-water lines, hot water generating equipment with capacity and recovery rate, backflow prevention, and wastewater line connections;

d. Lighting schedule with protectors;

(1) At least 110 lux (10 foot candles) at a distance of 75 cm (30 inches) above the floor, in walk-in refrigeration units and dry food storage areas and in other areas and rooms during periods of cleaning;

(2) At least 220 lux (20 foot candles):

(a) At a surface where food is provided for consumer self-service such as buffets and salad bars or where fresh produce or packaged foods are sold or offered for consumption;

(b) Inside equipment such as reach-in and under-counter refrigerators;

(c) At a distance of 75 cm (30 inches) above the floor in areas used for handwashing, warewashing, and equipment and utensil storage, and in toilet rooms; and

(3) At least 540 lux (50 foot candles) at a surface where a food employee is working with food or working with utensils or equipment such as knives, slicers, grinders, or saws where employee safety is a factor.

e. Food Equipment schedule to include make and model numbers and listing of equipment that is certified or classified for sanitation by an ANSI accredited certification program (when applicable).

f. Source of water supply and method of sewage disposal. Provide the location of these facilities and submit evidence that state and local regulations are complied with;

g. A color coded flow chart demonstrating flow patterns for:

- food (receiving, storage, preparation, service);
- food and dishes (portioning, transport, service);
- dishes (clean, soiled, cleaning, storage);
- utensil (storage, use, cleaning);
- trash and garbage (service area, holding, storage);

h. Ventilation schedule for each room;

i. A mop sink or curbed cleaning facility with facilities for hanging wet mops;

- j. Garbage can washing area/facility;
- k. Cabinets for storing toxic chemicals;
- l. Dressing rooms, locker areas, employee rest areas, and/or coat rack as required;
- m. Completed Section 1;
- n. Site plan (plot plan)

## FOOD PREPARATION REVIEW

Check categories of Potentially Hazardous Foods (PHF's) to be handled, prepared and served.

<u>CATEGORY</u> *	<u>(YES)</u>	<u>(NO)</u>
1. Thin meats, poultry, fish, eggs (hamburger; sliced meats; fillets)	( )	( )
2. Thick meats, whole poultry (roast beef; whole turkey, chickens, hams)	( )	( )
3. Cold processed foods (salads, sandwiches, vegetables)	( )	( )
4. Hot processed foods (soups, stews, rice/noodles, gravy, chowders, casseroles)	( )	( )
5. Bakery goods (pies, custards, cream fillings & toppings)	( )	( )
6. Other _____ _____		

\* A generic HACCP plan for each category of food may be available from the regulatory authority for reference.

### ***PLEASE CIRCLE/ANSWER THE FOLLOWING QUESTIONS***

#### **FOOD SUPPLIES:**

1. Are all food supplies from inspected and approved sources? YES / NO
2. What are the projected frequencies of deliveries for Frozen foods \_\_\_\_\_,  
Refrigerated foods \_\_\_\_\_, and Dry goods \_\_\_\_\_.
3. Provide information on the amount of space (in cubic feet) allocated for:  
Dry storage \_\_\_\_\_,  
Refrigerated Storage \_\_\_\_\_, and  
Frozen storage \_\_\_\_\_.
4. How will dry goods be stored off the floor?

---

**COLD STORAGE:**

1. Is adequate and approved freezer and refrigeration available to store frozen foods frozen, and refrigerated foods at 41EF (5EC) and below? YES / NO

Provide the method used to calculate cold storage requirements.

2. Will raw meats, poultry and seafood be stored in the same refrigerators and freezers with cooked/ready-to-eat foods? YES / NO

If yes, how will cross-contamination be prevented?

---

---

---

3. Does each refrigerator/freezer have a thermometer? YES / NO

Number of refrigeration units: \_\_\_\_\_

Number of freezer units: \_\_\_\_\_

4. Is there a bulk ice machine available? YES / NO

**THAWING FROZEN POTENTIALLY HAZARDOUS FOOD:**

Please indicate by checking the appropriate boxes how frozen potentially hazardous foods (PHF's) in each category will be thawed. More than one method may apply. Also, indicate where thawing will take place.

<b>Thawing Method</b>	<b>*THICK FROZEN FOODS</b>	<b>*THIN FROZEN FOODS</b>
Refrigeration		
Running Water Less than 70EF(21EC)		
Microwave (as part of cooking process)		
Cooked from Frozen state		
Other (describe)		

\* Frozen foods: approximately one inch or less = thin, and more than an inch = thick.

**COOKING:**

1. Will food product thermometers be used to measure final cooking/reheating temperatures of PHF's? YES / NO

What type of temperature measuring device:\_\_\_\_\_

**Minimum cooking time and temperatures of product utilizing convection and conduction heating equipment:**

beef roasts	130EF (121 min)
solid seafood pieces	145EF (15 sec)
other PHF s	145EF (15 sec)
eggs:	
Immediate service	145EF (15 sec)
pooled*	155EF (15 sec)
(*pasteurized eggs must be served to a highly susceptible population)	
pork	145EF (15 sec)
comminuted meats/fish	155EF (15 sec)
poultry	165EF (15 sec)
reheated PHF s	165EF (15 sec)

2. List types of cooking equipment.

---

---

**HOT/COLD HOLDING:**

1. How will hot PHF's be maintained at 140EF (60EC) or above during holding for service? Indicate type and number of hot holding units.

---

---

---

2. How will cold PHF's be maintained at 41EF (5EC) or below during holding for service? Indicate type and number of cold holding units.

---

---

---

**COOLING:**

Please indicate by checking the appropriate boxes how PHF's will be cooled to 41EF (5EC) within 6 hours (140EF to 70EF in 2 hours and 70EF to 41EF in 4 hours). Also, indicate where the cooling will take place.

<b>COOLING METHOD</b>	<b>THICK MEATS</b>	<b>THIN MEATS</b>	<b>THIN SOUPS/ GRAVY</b>	<b>THICK SOUPS/ GRAVY</b>	<b>RICE/ NOODLES</b>
Shallow Pans					
Ice Baths					
Reduce Volume or Size					
Rapid Chill					
Other (describe)					

**REHEATING:**

1. How will PHF s that are cooked, cooled, and reheated for hot holding be reheated so that all parts of the food reach a temperature of at least 165EF for 15 seconds. Indicate type and number of units used for reheating foods.

---

---

---

2. How will reheating food to 165EF for hot holding be done rapidly and within 2 hours?

---

---

---

**PREPARATION:**

1. Please list categories of foods prepared more than 12 hours in advance of service.

---

---

---

2. Will food employees be trained in good food sanitation practices? YES / NO

Method of training:

\_\_\_\_\_

Number(s) of employees: \_\_\_\_\_

Dates of completion: \_\_\_\_\_

3. Will disposable gloves and/or utensils and/or food grade paper be used to prevent handling of ready-to-eat foods? YES / NO

4. Is there a written policy to exclude or restrict food workers who are sick or have infected cuts and lesions? YES / NO

Please describe briefly:

\_\_\_\_\_  
\_\_\_\_\_  
\_\_\_\_\_

Will employees have paid sick leave? YES / NO

5. How will cooking equipment, cutting boards, counter tops and other food contact surfaces which cannot be submerged in sinks or put through a dishwasher be sanitized?

Chemical Type: \_\_\_\_\_

Concentration: \_\_\_\_\_

Test Kit: YES / NO

6. Will ingredients for cold ready-to-eat foods such as tuna, mayonnaise and eggs for salads and sandwiches be pre-chilled before being mixed and/or assembled? YES/NO

If not, how will ready-to-eat foods be cooled to 41EF?

\_\_\_\_\_  
\_\_\_\_\_  
\_\_\_\_\_

7. Will all produce be washed on-site prior to use? YES / NO

Is there a planned location used for washing produce? YES / NO

Describe \_\_\_\_\_

\_\_\_\_\_  
\_\_\_\_\_

If not, describe the procedure for cleaning and sanitizing multiple use sinks between uses.

---

---

---

---

8. Describe the procedure used for minimizing the length of time PHF's will be kept in the temperature danger zone (41EF - 140EF) during preparation.

---

---

---

---

9. Provide a HACCP plan for specialized processing methods such as vacuum packaged food items prepared on-site or otherwise required by the regulatory authority.

10. Will the facility be serving food to a highly susceptible population? YES / NO  
If yes, how will the temperature of foods be maintained while being transferred between the kitchen and service area?

---

---

---

**A. FINISH SCHEDULE**

Applicant must indicate which materials (quarry tile, stainless steel, 4" plastic covered molding, etc.) will be used in the following areas.

	<b>FLOOR</b>	<b>COVING</b>	<b>WALLS</b>	<b>CEILING</b>
<b>Kitchen</b>				
<b>Bar</b>				
<b>Food Storage</b>				
<b>Other Storage</b>				
<b>Toilet Rooms</b>				
<b>Dressing Rooms</b>				
<b>Garbage &amp; Refuse Storage</b>				
<b>Mop Service Basin Area</b>				
<b>Warewashing Area</b>				
<b>Walk-in Refrigerators and Freezers</b>				

**B. INSECT AND RODENT CONTROL**

*APPLICANT: Please check appropriate boxes.*

	<b>YES</b>	<b>NO</b>	<b>NA</b>
1. Will all outside doors be self-closing and rodent proof ?	( )	( )	( )
2. Are screen doors provided on all entrances left open to the outside?	( )	( )	( )
3. Do all openable windows have a minimum #16 mesh screening?	( )	( )	( )
4. Is the placement of electrocution devices identified on the plan?	( )	( )	( )
5. Will all pipes & electrical conduit chases be sealed; ventilation systems exhaust and intakes protected?	( )	( )	( )
6. Is area around building clear of unnecessary brush, litter, boxes and other harborage?	( )	( )	( )
7. Will air curtains be used? If yes, where? _____	( )	( )	( )

**C. GARBAGE AND REFUSE**

**Inside**

8. Do all containers have lids?	( )	( )	( )
9. Will refuse be stored inside? If so, where? _____ _____	( )	( )	( )
10. Is there an area designated for garbage can or floor mat cleaning?	( )	( )	( )

<u>Outside</u>	YES	NO	NA
11. Will a dumpster be used? Number _____ Size _____ Frequency of pickup _____ Contractor _____	( )	( )	( )

12. Will a compactor be used? Number _____ Size _____ Frequency of pick up _____ Contractor _____	( )	( )	( )
--	-----	-----	-----

13. Will garbage cans be stored outside?	( )	( )	( )
--	-----	-----	-----

14. Describe surface and location where dumpster/compactor/garbage cans are to be stored

---



---



---

15. Describe location of grease storage receptacle

---



---



---

16. Is there an area to store recycled containers?	( )	( )	( )
--	-----	-----	-----

Describe \_\_\_\_\_

---

- Indicate what materials are required to be recycled;
- ( ) Glass
  - ( ) Metal
  - ( ) Paper
  - ( ) Cardboard
  - ( ) Plastic

17. Is there any area to store returnable damaged goods?	( )	( )	( )
--	-----	-----	-----

**D. PLUMBING CONNECTIONS**

	<b>AIR GAP</b>	<b>AIR BREAK</b>	<b>*INTEGRAL TRAP</b>	<b>* P TRAP</b>	<b>VACUUM BREAKER</b>	<b>CONDENSATE PUMP</b>
<b>18. Toilet</b>						
<b>19. Urinals</b>						
<b>20. Dishwasher</b>						
<b>21. Garbage Grinder</b>						
<b>22. Ice machines</b>						
<b>23. Ice storage bin</b>						
<b>24. Sinks</b> a. Mop b. Janitor c. Handwash d. 3 Compartment e. 2 Compartment f. 1 Compartment g. Water Station						
<b>25. Steam tables</b>						
<b>26. Dipper wells</b>						
<b>27. Refrigeration condensate/ drain lines</b>						
<b>28. Hose connection</b>						
<b>29. Potato peeler</b>						
<b>30. Beverage Dispenser w/carbonator</b>						
<b>31. Other</b> _____						

\* **TRAP:** A fitting or device which provides a liquid seal to prevent the emission of sewer gases without materially affecting the flow of sewage or waste water through it. An integral trap is one that is built directly into the fixture, e.g., a toilet fixture. A P trap is a fixture trap that provides a liquid seal in the shape of the letter P. Full S traps are prohibited.

32. Are floor drains provided & easily cleanable, if so, indicate location:

---

---

**E. WATER SUPPLY**

33. Is water supply public ( ) or private ( ) ?

34. If private, has source been approved? YES ( ) NO ( ) PENDING ( )

Please attach copy of written approval and/or permit.

35. Is ice made on premises ( ) or purchased commercially ( ) ?

If made on premise, are specifications for the ice machine provided? YES ( ) NO ( )

Describe provision for ice scoop storage: \_\_\_\_\_

Provide location of ice maker or bagging operation \_\_\_\_\_

36. What is the capacity of the hot water generator?

---

37. Is the hot water generator sufficient for the needs of the establishment?

Provide calculations for necessary hot water (see Part 5 & Part 9 Under Section III in this manual)

38. Is there a water treatment device? YES ( ) NO ( )

If yes, how will the device be inspected & serviced?

---

---

39. How are backflow prevention devices inspected & serviced?

---

---

**F. SEWAGE DISPOSAL**

40. Is building connected to a municipal sewer? YES ( ) NO ( )

41. If no, is private disposal system approved? YES ( ) NO ( ) PENDING ( )

Please attach copy of written approval and/or permit.

42. Are grease traps provided? YES ( ) NO ( )  
If so, where? \_\_\_\_\_  
Provide schedule for cleaning & maintenance \_\_\_\_\_

**G. DRESSING ROOMS**

43. Are dressing rooms provided? YES ( ) NO ( )

44. Describe storage facilities for employees' personal belongings (i.e., purse, coats, boots, umbrellas, etc.) \_\_\_\_\_  
\_\_\_\_\_

**H. GENERAL**

45. Are insecticides/rodenticides stored separately from cleaning & sanitizing agents?  
YES ( ) NO ( )  
)  
Indicate location: \_\_\_\_\_  
\_\_\_\_\_

46. Are all toxics for use on the premise or for retail sale (this includes personal medications), stored away from food preparation and storage areas? YES ( ) NO ( )

47. Are all containers of toxics including sanitizing spray bottles clearly labeled?  
YES ( ) NO ( )

48. Will linens be laundered on site? YES ( ) NO ( )  
If yes, what will be laundered and where? \_\_\_\_\_  
\_\_\_\_\_  
If no, how will linens be cleaned? \_\_\_\_\_

49. Is a laundry dryer available? YES ( ) NO ( )

50. Location of clean linen storage: \_\_\_\_\_  
\_\_\_\_\_

51. Location of dirty linen storage: \_\_\_\_\_  
\_\_\_\_\_

52. Are containers constructed of safe materials to store bulk food products?  
YES ( ) NO ( )  
)  
Indicate type: \_\_\_\_\_  
\_\_\_\_\_

53. Indicate all areas where exhaust hoods are installed:

LOCATION	FILTERS &/OR EXTRACTION DEVICES	SQUARE FEET	FIRE PROTECTION	AIR CAPACITY CFM	AIR MAKEUP CFM

54. How is each listed ventilation hood system cleaned?

---

**I. SINKS**

55. Is a mop sink present? YES ( ) NO ( )  
 If no, please describe facility for cleaning of mops and other equipment:

---



---

56. If the menu dictates, is a food preparation sink present?  
 YES ( ) NO ( )

**J. DISHWASHING FACILITIES**

57. Will sinks or a dishwasher be used for warewashing?  
 Dishwasher ( )  
 Two compartment sink ( )  
 Three compartment sink ( )

58. Dishwasher  
 Type of sanitization used:  
 Hot water (temp. provided) \_\_\_\_\_  
 Booster heater \_\_\_\_\_  
 Chemical type \_\_\_\_\_

Is ventilation provided? YES ( ) NO ( )

59. Do all dish machines have templates with operating instructions?  
YES ( ) NO ( )

60. Do all dish machines have temperature/pressure gauges as required that are accurately working?  
YES ( ) NO ( )

61. Does the largest pot and pan fit into each compartment of the pot sink?  
YES ( ) NO ( )  
If no, what is the procedure for manual cleaning and sanitizing?

---

---

62. Are there drain boards on both ends of the pot sink?  
YES ( ) NO ( )

63. What type of sanitizer is used?  
Chlorine ( )  
Iodine ( )  
Quaternary ammonium ( )  
Hot water ( )  
Other ( )

64. Are test papers and/or kits available for checking sanitizer concentration?  
YES ( ) NO ( )

**K. HANDWASHING/TOILET FACILITIES**

65. Is there a handwashing sink in each food preparation and warewashing area?  
YES ( ) NO ( )

66. Do all handwashing sinks, including those in the restrooms, have a mixing valve or combination faucet?  
YES ( ) NO ( )

67. Do self-closing metering faucets provide a flow of water for at least 15 seconds without the need to reactivate the faucet?  
YES ( ) NO ( )

68. Is hand cleanser available at all handwashing sinks?  
YES ( ) NO ( )

69. Are hand drying facilities (paper towels, air blowers, etc.) available at all handwashing

sinks? YES ( ) NO ( )

70. Are covered waste receptacles available in each restroom?  
YES ( ) NO ( )

71. Is hot and cold running water under pressure available at each handwashing sink?  
YES ( ) NO ( )

72. Are all toilet room doors self-closing? YES ( ) NO ( )

73. Are all toilet rooms equipped with adequate ventilation?  
YES ( ) NO ( )

74. If required, is a handwashing sign posted in each employee restroom?  
YES ( ) NO ( )

**L. SMALL EQUIPMENT REQUIREMENTS**

75. Please specify the number, location, and types of each of the following:  
Slicers \_\_\_\_\_  
Cutting boards \_\_\_\_\_  
Can openers \_\_\_\_\_  
Mixers \_\_\_\_\_  
Floor mats \_\_\_\_\_  
Other \_\_\_\_\_

\*\*\*\*\*

**STATEMENT: I hereby certify that the above information is correct, and I fully understand that any deviation from the above without prior permission from this Health Regulatory Office may nullify final approval.**

Signature(s) \_\_\_\_\_

\_\_\_\_\_  
owner(s) or responsible representative(s)

Date: \_\_\_\_\_

\*\*\*\*\*

**Approval of these plans and specifications by this Regulatory Authority does not indicate compliance with any other code, law or regulation that may be required--federal, state, or local. It further does not constitute endorsement or acceptance of the**

completed establishment (structure or equipment). A preopening inspection of the establishment with equipment in place & operational will be necessary to determine if it complies with the local and state laws governing food service establishments.

## **SECTION II**

# **REGULATORY AUTHORITY COMPLIANCE REVIEW LIST AND APPROVAL/DISAPPROVAL FORM**



**REGULATORY AUTHORITY COMPLIANCE REVIEW LIST**

	<u>SAT.</u>	<u>UNSAT.</u>	<u>N/A</u>	<u>INSUFF.</u> <u>INFORM.</u>
<b>1. Food Preparation Review</b>				
Raw food prep table(s) (as menu dictates)	( )	( )	( )	( )
Raw food prep sink(s) (as menu dictates)	( )	( )	( )	( )
Adequate refrigeration	( )	( )	( )	( )
Adequate cold holding facilities	( )	( )	( )	( )
Adequate hot holding facilities	( )	( )	( )	( )
Adequate hot food preparation equip.	( )	( )	( )	( )
Vacuum packaging (HACCP plan)	( )	( )	( )	( )
<b>2. Utensil &amp; Equipment Storage</b>				
Clean	( )	( )	( )	( )
Soiled	( )	( )	( )	( )
Counter mounted equip.	( )	( )	( )	( )
Floor mounted equip.	( )	( )	( )	( )
Vacuum packaging equip.	( )	( )	( )	( )
Bulk food	( )	( )	( )	( )
Self service				
Salad	( )	( )	( )	( )
Hot/Cold Buffet	( )	( )	( )	( )

	<u>SAT.</u>	<u>UNSAT.</u>	<u>N/A</u>	<u>INSUFF.</u> <u>INFORM.</u>
<b>3. Kitchen Equipment</b>				
Space between units or wall closed; moveable, or adequate space for easy cleaning	( )	( )	( )	( )
Work space & aisles sufficient	( )	( )	( )	( )
Storage 6" off floor	( )	( )	( )	( )
Countertops & cutting boards of suitable material	( )	( )	( )	( )
Self serve food area adequately protected	( )	( )	( )	( )
Approved thermometer for each refrigerator & freezer, and for taking food temperatures	( )	( )	( )	( )
<b>4. Finish Schedule</b>				
Kitchen	( )	( )	( )	( )
Bar	( )	( )	( )	( )
Food Storage	( )	( )	( )	( )
Other Storage	( )	( )	( )	( )
Toilet Rooms	( )	( )	( )	( )
Dressing Rooms	( )	( )	( )	( )
Garbage & Refuse Storage	( )	( )	( )	( )
Mop Service Area	( )	( )	( )	( )
Warewashing Area	( )	( )	( )	( )
Walk-in refrigerator & freezers	( )	( )	( )	( )
<b>5. Plumbing</b>				
Cross Connections	( )	( )	( )	( )
Water Supply	( )	( )	( )	( )
Sewage Disposal	( )	( )	( )	( )
Hand Sinks	( )	( )	( )	( )
Dishwashing & Pot Sinks	( )	( )	( )	( )
Grease Traps	( )	( )	( )	( )

Service/Janitorial Sinks	( )	( )	( )	( )
Hot Water	( )	( )	( )	( )

	<u>SAT.</u>	<u>UNSAT.</u>	<u>N/A</u>	<u>INSUFF INFORM.</u>
--	-------------	---------------	------------	---------------------------

**6. Physical Facilities**

Dressing Rooms	( )	( )	( )	( )
Separate Toxic Storage	( )	( )	( )	( )
Laundry Facilities	( )	( )	( )	( )
Linen Storage	( )	( )	( )	( )
Lighting	( )	( )	( )	( )
Food Storage	( )	( )	( )	( )
Dry goods storage	( )	( )	( )	( )

**7. Refuse & Pest Control**

Garbage & Refuse Storage	( )	( )	( )	( )
Insect & Rodent Control Measures	( )	( )	( )	( )

**8. Ventilation**

Exhaust Hoods	( )	( )	( )	( )
Ventilation	( )	( )	( )	( )

**9. Employee Restrooms**

Location	( )	( )	( )	( )
Number _____	( )	( )	( )	( )
Soap Dispensers	( )	( )	( )	( )
Hand Drying	( )	( )	( )	( )
Lavatories	( )	( )	( )	( )
Water Closets	( )	( )	( )	( )
Urinals	( )	( )	( )	( )
Hot & Cold Water Provided ( )	( )	( )	( )	( )
Waste Receptacles ( )	( )	( )	( )	( )

**10. Patron Restrooms**

Location	( )	( )	( )	( )
Number _____	( )	( )	( )	( )
Soap Dispensers	( )	( )	( )	( )
Hand Drying	( )	( )	( )	( )
Lavatories	( )	( )	( )	( )
Water Closets	( )	( )	( )	( )



---

## **SECTION III**

# **FOOD ESTABLISHMENT GUIDE FOR DESIGN, INSTALLATION, AND CONSTRUCTION RECOMMENDATIONS**

# FOOD ESTABLISHMENT GUIDE

## FOR DESIGN, INSTALLATION, AND

### CONSTRUCTION RECOMMENDATIONS

#### STATEMENT OF PURPOSE

This technical reference is intended to provide guidance and assistance in complying with nationally recognized food safety standards. It includes design, installation and construction recommendations regarding food equipment and facilities. This document can be used by both the Regulatory Health Authority and the food establishment applicant.

The goal of this document is to promote the uniform design and construction standards for food facilities which are not only conducive to safe food handling and sanitary facility maintenance but which encourage both.

\*\*\*\*\*

All equipment in food establishments should comply with the design and construction standards of appropriate nationally recognized standards and/or code requirements and bear the certification mark of an ANSI accredited organization (e.g. NSF,UL, ETL).

## TABLE OF CONTENTS

	PAGE
<b>PART 1</b> MENU.....	29
<b>PART 2</b> FACILITIES TO MAINTAIN PRODUCT TEMPERATURE....	31
<b>PART 3</b> FACILITIES TO PROTECT FOOD.....	41
<b>PART 4</b> HANDWASHING.....	45
<b>PART 5</b> WATER SUPPLY AND SEWAGE DISPOSAL.....	47
<b>PART 6</b> FOOD EQUIPMENT AND INSTALLATION.....	48
<b>PART 7</b> DRY STORAGE CONSIDERATION .....	56
<b>PART 8</b> WAREWASHING FACILITIES.....	79
<b>PART 9</b> HOT WATER SUPPLY REQUIREMENTS.....	85
<b>PART 10</b> FINISH SCHEDULE - FLOORS, WALLS, CEILINGS.....	103
<b>PART 11</b> TOILET FACILITIES.....	107
<b>PART 12</b> PLUMBING AND CROSS CONNECTION CONTROL.....	108
<b>PART 13</b> INSECT AND RODENT CONTROL.....	117
<b>PART 14</b> LIGHTING.....	118
<b>PART 15</b> VENTILATION.....	119
<b>PART 16</b> UTILITY FACILITY.....	132
<b>PART 17</b> DRESSING AND LOCKER ROOMS.....	134
<b>PART 18</b> GARBAGE & REFUSE STORAGE .....	135
<b>REFERENCES</b> .....	136

## **PART 1 - MENU**

The menu is an integral part of the Plan Review Process. The menu or a listing of all of the food and beverage items to be offered at the food service establishment must be submitted by the applicant to the regulatory authority with the submission of all other Plan Review application documents.

As with the inspection process, the plan review process should focus on the food and what will happen to the food. The source and quantity of food to be served should be reviewed along with the preparation and post-preparation operations and the proposed storage practices.

Food preparation processes should be evaluated to determine the types and volumes of foods to be prepared. Special attention should be given to the review of complex food processes which will involve:

- multiple ingredients being assembled or mixed
- potentially hazardous foods
- foods which will be prepared or held for several hours prior to service
- foods requiring cooling and reheating
- multiple step processing (passing through the critical temperature zone, 140EF to 41EF more than once).

The style of food service should also be reviewed. The style of food service may be cook-to-order (cook-serve), self-service (buffet or salad bar), service of pre-packaged foods, service of large volumes of food, food preparation requiring multiple steps and handling, etc.

A suggested system of menu evaluation involves the review of categories of foods and their required preparation, i.e.:

- all food needs to come from an inspected and approved source
- thin meats such as poultry, fish, eggs (hamburgers, sliced meats, & fillets)
- thick meats and whole poultry (roast beef, whole turkey, whole chickens, & hams)
- cold processed foods (salad, sandwiches, vegetables)
- hot processed foods (soups, stews, casseroles)
- bakery goods

This system is useful since the critical control points for each process remain the same regardless of the individual menu ingredients.

The menu for a food service establishment dictates the space and equipment requirements for the safe preparation and service of various food items. The menu will determine if the proposed receiving and delivery areas, storage area, preparation and handling areas, and thawing, cooking, and reheating areas are available and adequate to

handle the types and volumes of foods being served.

When looking at the menu, evaluate the flow patterns for the preparation of the foods to be served to be sure that the lay-out of the facility provides an adequate separation of raw ingredients from ready-to-eat foods, that the traffic patterns are not crossing paths with waste items and other sources of contamination.

With proper understanding of the menu, the plans for food service establishments can be reviewed to assure that the food items proposed can be protected during the service operation.

---

Other references are available for additional formulas and information. One such reference includes: Kazarian, E. A., Ph.D., Food Service Facilities Planning. Copyright Van Nostrand Reinhold, NY., 1989.

## **PART 2- FACILITIES TO MAINTAIN PRODUCT TEMPERATURE**

Sufficient hot-holding and cold-holding facilities shall comply with the standards of NSF or equivalent, and shall be designed, constructed and installed in conformance with the requirements of these standards.

### **REFRIGERATION FACILITIES SIZING AND DESIGN**

The plan review for storage needs to provide adequate refrigeration facilities for the proper storage, transportation, display, and service of potentially hazardous foods. Specific refrigeration needs will be based upon the menu, number of meals, frequency of delivery, and preparation in advance of service. All refrigerators must be capable of maintaining potentially hazardous foods (PHF) at 41EF or below.

If potentially hazardous foods are prepared a day or more in advance of service, a rapid cooling procedure capable of cooling potentially hazardous foods from 140EF to 41EF within 6 hours (140EF to 70EF in 2 hrs. & 70EF to 41EF in 4 hrs.) should be provided. The capacity of the rapid cooling facilities must be sufficient to accommodate the volume of food required to be cooled to 41EF within 6 hours.

Provide point-of-use refrigerators and freezers at work stations for operations requiring preparation and handling of potentially hazardous foods. Refrigeration units, unless designed for such use, should not be located directly adjacent to cooking equipment or other high heat producing equipment which may tax the cooling system's operation.

### **SIZING CONSIDERATION FOR CALCULATING TOTAL REFRIGERATED STORAGE NEEDS, INCLUDING WALK-INS**

To plan reserve storage, the following need to be considered: menu, type of service, number of meals per day, number of deliveries per week and adequate air ventilation in the area where refrigeration system will be located.

The following is a suggested formula to establish required reserve storage (note: only 40% of any walk-in unit actually provides usable space):

Total Interior Storage Volume Needed:

$$\frac{\text{Vol. per meal (Cu. ft.)} \times \text{number of meals}}{.40}$$

Below are estimated typical meal volumes for each of three types of refrigerated storage:

Meat, Poultry and Seafood	=	.010-.030 Cu. ft. per meal
Dairy	=	.007-.015 Cu. ft. per meal
Vegetables and fruit	=	.020-.040 Cu. ft. per meal

Thus for a restaurant serving 1000 meals between deliveries (assume a minimum of 4 day storage) the following storage capacities are needed:

$$\text{Meat refrigerated storage} = \frac{.030 \text{ Cu. ft./meal} \times 1000 \text{ meals}}{.40}$$

$$= 75 \text{ Cu. ft.}$$

$$\text{Vegetable refrigerated storage} = \frac{.040 \text{ Cu. ft./meal} \times 1000 \text{ meals}}{.40}$$

$$= 100 \text{ Cu. ft.}$$

$$\text{Dairy refrigerated storage} = \frac{.015 \text{ Cu. ft./meal} \times 1000 \text{ meals}}{.40}$$

$$= 37.5 \text{ Cu. ft.}$$

To calculate the interior storage space (in square feet) required for the above example, divide the volume (Cu. ft), in each case, by the height of the unit.

Example:

$$\text{For meat refrigerated storage} = \frac{75 \text{ Cu. ft.}}{6 \text{ ft. (height)}}$$

$$= 12.5 \text{ sq. ft.}$$

The interior floor area would have to be 12.5 sq. ft. to accommodate refrigeration storage of meat for 1000 meals.

To estimate total interior volume or space, add together the requirements for each type of food.

To convert interior measurements to exterior floor area, multiply by 1.25. Thus, for meat storage, in the above example an exterior floor area = 1.25 x 12.5 sq. ft., or 15.6 sq. ft. would be needed.

## ADDITIONAL RECOMMENDATIONS FOR REFRIGERATED STORAGE FACILITIES

- A. Shelving for walk-in and reach-in refrigeration units should be equipment that is certified or classified for sanitation by an ANSI accredited certification program.
- B. Interior finishes of walk-in and reach-in refrigeration units should be certified or classified for sanitation by an ANSI accredited certification program. Galvanized metal is not recommended because of its tendency to rust.
- C. All refrigeration units must have numerically scaled indicating thermometers accurate to  $\pm 3\text{EF}$ . The temperature sensing device must be located in the unit to measure air temperature in the warmest part. All such thermometers should have an externally mounted indicator to facilitate easy reading of the temperature of the unit. Refrigerators and freezers shall be capable of maintaining appropriate temperatures when evaluated under test conditions of an ANSI accredited certification program.
- D. Air circulation within refrigeration and freezer units should not be obstructed and should allow for an even and consistent flow of cold air throughout the units.

Refrigeration Unit maximum operating temperature (cabinet air) should be:

<u>Type</u>	<u>Max Temp</u>	<u>Max Compressor Operating time</u>
Refrigerated buffet units	Cabinet air temp 41EF Food temp 33-41EF	70%
Storage & display refrigerators	Cabinet air temp 41EF Food temp 33-41EF	70%
Storage & display freezer	Cabinet air temp 0EF Food Frozen	80%

Rapid pull down refrigeration units must be capable of cooling cooked PHF s from 140EF to 70EF within 2 hours, and from 70EF to 41EF within 4 hours or less.

- E. Approved coved juncture base around the interior.
- F. Approved coved junction base around the exterior.
- G. Approved enclosure between the top of the unit and the ceiling if this space is twenty-four inches or less. Fixed equipment shall be spaced to allow for cleaning along the sides and behind, or sealed to adjoining equipment or walls.

- H. Refrigeration units should not be installed exterior to the building if non-packaged foods will be transported from the unit to the food establishment.
- I. If the walk-in floors are water-flushed for cleaning or receive the discharge of liquid waste or excessive melt water, the floors should be non-absorbent (i.e. quarry tile or equal) with silicone or epoxy impregnated grout and, sloped to drain. Local jurisdictions may require drains to be located outside of the cooling box within 5 feet of the cooler box.
- J. Walk-in freezer doors should be equipped with pressure relief ports.
- K. All walk-in units should be constructed and installed in accordance with nationally recognized standards and/or code requirements and bear the certification mark of an ANSI accredited organization (e.g. NSF, UL, ETL).
- L. Each walk-in unit shall be equipped with lighting that provides 10 foot candles of light throughout the unit when it is full of product.

#### HOT HOLDING AND REHEATING FACILITIES

The hot holding facilities must be capable of maintaining potentially hazardous foods at an internal temperature of 140EF or above during display, service and holding periods.

Reheating equipment must be capable of raising the internal temperature of potentially hazardous foods rapidly (within a maximum of 2 hours) to at least 165EF. Appropriate product thermometers will be required to monitor the food temperature.

#### SAMPLE COLD STORAGE CALCULATIONS

Cited on the next few pages are examples of cold storage calculations prepared by the North Carolina Department of Health, Food Lodging and Institutional Sanitation Branch, Plan Review Subcommittee.

The following three charts are based on the volume of the meals, number of meals served and frequency of delivery.

To calculate the interior storage space required for walk-in refrigeration units for the following charts to square feet, simply divide the cu. ft. (volume), in each case by the height of the unit.

### MEAT AND POULTRY COLD STORAGE CHART FOR WALK-IN UNITS

number of meals served between deliveries	storage per 0.01 Cu. Ft. per meal per number meals served	storage per 0.015 Cu. Ft. per meal per number meals served	storage per 0.020 Cu. Ft. per meal per number meals served	storage per 0.025 Cu. Ft. per meal per number meals served	storage per 0.03 Cu. Ft. per meal per number meals served
200	5	7.50	10.00	12.50	15.00
250	6.25	9.38	12.50	15.63	18.75
300	7.50	11.25	15.00	18.75	22.50
350	8.75	13.13	17.50	21.88	26.25
400	10.00	15.00	20.00	25.00	30.00
450	11.25	16.88	22.50	28.13	33.75
500	12.50	18.75	25.00	31.25	37.50
550	13.75	20.63	27.50	34.38	41.25
600	15.00	22.50	30.00	37.50	45.00
650	16.25	24.38	32.50	40.63	48.75
700	17.50	26.25	35.00	43.75	52.50
750	18.75	28.13	37.50	46.88	56.25
800	20.00	30.00	40.00	50.00	60.00
850	21.25	31.88	42.50	53.13	63.75
900	22.50	33.75	45.00	56.25	67.50
950	23.75	35.63	47.50	59.38	71.25
1000	25.00	37.50	50.00	62.50	75.00
1050	26.25	39.38	52.50	65.63	78.75
1100	27.50	41.25	55.00	68.75	82.50
1150	28.75	43.13	57.50	71.88	86.25
1200	30.00	45.00	60.00	75.00	90.00
1250	31.25	46.88	62.50	78.13	93.75
1300	32.50	48.75	65.00	81.25	97.50
1350	33.75	50.63	67.50	84.38	101.25
1400	35.00	52.50	70.00	87.50	105.00
1450	36.25	54.38	72.50	90.63	108.75
1500	37.50	56.25	75.00	93.75	112.50
1550	38.75	58.13	77.50	96.88	116.25
1600	40.00	60.00	80.00	100.00	120.00
1650	41.25	61.88	82.50	103.13	123.75
1700	42.50	63.75	85.00	106.25	127.50
1750	43.75	65.63	87.50	109.38	131.25
1800	45.00	67.50	90.00	112.50	135.00
1850	46.25	69.38	92.50	115.63	138.75
1900	47.50	71.25	95.00	118.75	142.50
1950	48.75	73.13	97.50	121.88	146.25
2000	50.00	75.00	100.00	125.00	150.00

## VEGETABLE AND FRUIT COLD STORAGE CHART FOR WALK-IN UNITS

number of meals served between deliveries	storage per 0.020 Cu. Ft. per meal per number meals served	storage per 0.025 Cu. Ft. per meal per number meals served	storage per 0.030 Cu. Ft. per meal per number meals served	storage per 0.035 Cu. Ft. per meal per number meals served	storage per 0.040 Cu. Ft. per meal per number meals served
200	10.00	12.50	15.00	17.50	20.00
250	12.50	15.63	18.75	21.88	25.00
300	15.00	18.75	22.50	26.25	30.00
350	17.50	21.88	26.25	30.63	35.00
400	20.00	25.00	30.00	35.00	40.00
450	22.50	28.13	33.75	39.38	45.00
500	25.00	31.25	37.50	43.75	50.00
550	27.50	34.38	41.25	48.13	55.00
600	30.00	37.50	45.00	52.50	60.00
650	32.50	40.63	48.75	56.88	65.00
700	35.00	43.75	52.50	61.25	70.00
750	37.50	46.88	56.25	65.63	75.00
800	40.00	50.00	60.00	70.00	80.00
850	42.50	53.13	63.75	74.38	85.00
900	45.00	56.25	67.50	78.75	90.00
950	47.50	59.38	71.25	83.13	95.00
1000	50.00	62.50	75.00	87.50	100.00
1050	52.50	65.63	78.75	91.88	105.00
1100	55.00	68.75	82.50	96.25	110.00
1150	57.50	71.88	86.25	100.63	115.00
1200	60.00	75.00	90.00	105.00	120.00
1250	62.50	78.13	93.75	109.38	125.00
1300	65.00	81.25	97.50	113.75	130.00
1350	67.50	84.38	101.25	118.13	135.00
1400	70.00	87.50	105.00	122.50	140.00
1450	72.50	90.63	108.75	126.88	145.00
1500	75.00	93.75	112.50	131.25	150.00
1550	77.50	96.88	116.25	135.63	155.00
1600	80.00	100.00	120.00	140.00	160.00
1650	82.50	103.13	123.75	144.38	165.00
1700	85.00	106.25	127.50	148.75	170.00
1750	87.50	109.38	131.25	153.13	175.00
1800	90.00	112.50	135.00	157.50	180.00
1850	92.50	115.63	138.75	161.88	185.00
1900	95.00	118.75	142.50	166.25	190.00
1950	97.50	121.88	146.25	170.63	195.00
2000	100.00	125.00	150.00	175.00	200.00

## DAIRY COLD STORAGE CHART FOR WALK-IN UNITS

number of meals served between deliveries	storage per 0.007 Cu. Ft. per meal	cu. ft. per meal	storage per 0.009 Cu. Ft. per meal	cu. ft. per meal	storage per 0.011 Cu. Ft. per meal	cu. ft. per meal	storage per 0.013 Cu. Ft. per meal	cu. ft. per meal	storage per 0.015 Cu. Ft. per meal	cu. ft. per meal
	per number meals served		per number meals served		per number meals served		per number meals served		per number meals served	
200	3.50		4.50		5.50		6.50		7.50	
250	4.38		5.63		6.88		8.13		9.38	
300	5.25		6.75		8.25		9.75		11.25	
350	6.13		7.88		9.63		11.38		13.13	
400	7.00		9.00		11.00		13.00		15.00	
450	7.88		10.13		12.38		14.63		16.88	
500	8.75		11.25		13.75		16.25		18.75	
550	9.63		12.38		15.13		17.88		20.63	
600	10.50		13.50		16.50		19.50		22.50	
650	11.38		14.63		17.88		21.13		24.38	
700	12.25		15.75		19.25		22.75		26.25	
750	13.13		16.88		20.63		24.38		28.13	
800	14.00		18.00		22.00		26.00		30.00	
850	14.88		19.13		23.38		27.63		31.88	
900	15.75		20.25		24.75		29.25		33.75	
950	16.63		21.38		26.13		30.88		35.63	
1000	17.50		22.50		27.50		32.50		37.50	
1050	18.38		23.63		28.88		34.13		39.38	
1100	19.25		24.75		30.25		35.75		41.25	
1150	20.13		25.88		31.63		37.38		43.13	
1200	21.00		27.00		33.00		39.00		45.00	
1250	21.88		28.13		34.38		40.63		46.88	
1300	22.75		29.25		35.75		42.25		48.75	
1350	23.63		30.38		37.13		43.88		50.63	
1400	24.50		31.50		38.50		45.50		52.50	
1450	25.38		32.63		39.88		47.13		54.38	
1500	26.25		33.75		41.25		48.75		56.25	
1550	27.13		34.88		42.63		50.38		58.13	
1600	28.00		36.00		44.00		52.00		60.00	
1650	28.88		37.13		45.38		53.63		61.88	
1700	29.75		38.25		46.75		55.25		63.75	
1750	30.63		39.38		48.13		56.88		65.63	
1800	31.50		40.50		49.50		58.50		67.50	
1850	32.38		41.63		50.88		60.13		69.38	
1900	33.25		42.75		52.25		61.75		71.25	
1950	34.13		43.88		53.63		63.38		73.13	
2000	35.00		45.00		55.00		65.00		75.00	

## MEAT AND POULTRY COLD STORAGE CHART FOR REACH-IN UNITS

number of meals served between deliveries	storage per 0.01 Cu. Ft. per meal per number meals served	storage per 0.015 Cu. Ft. per meal per number meals served	storage per 0.020 Cu. Ft. per meal per number meals served	storage per 0.025 Cu. Ft. per meal per number meals served	storage per 0.03 Cu. Ft. per meal per number meals served
200	2.67	4.00	5.33	6.67	8.00
250	3.33	5.00	6.67	8.33	10.00
300	4.00	6.00	8.00	10.00	12.00
350	4.67	7.00	9.33	11.67	14.00
400	5.33	8.00	10.67	13.33	16.00
450	6.00	9.00	12.00	15.00	18.00
500	6.67	10.00	13.33	16.67	20.00
550	7.33	11.00	14.67	18.33	22.00
600	8.00	12.00	16.00	20.00	24.00
650	8.67	13.00	17.33	21.67	26.00
700	9.33	14.00	18.67	23.33	28.00
750	10.00	15.00	20.00	25.00	30.00
800	10.67	16.00	21.33	26.67	32.00
850	11.33	17.00	22.67	28.33	34.00
900	12.00	18.00	24.00	30.00	36.00
950	12.67	19.00	25.33	31.67	38.00
1000	13.33	20.00	26.67	33.33	40.00
1050	14.00	21.00	28.00	35.00	42.00
1100	14.67	22.00	29.33	36.67	44.00
1150	15.33	23.00	30.67	38.33	46.00
1200	16.00	24.00	32.00	40.00	48.00
1250	16.67	25.00	33.33	41.67	50.00
1300	17.33	26.00	34.67	43.33	52.00
1350	18.00	27.00	36.00	45.00	54.00
1400	18.67	28.00	37.33	46.67	56.00
1450	19.33	29.00	38.67	48.33	58.00
1500	20.00	30.00	40.00	50.00	60.00
1550	20.67	31.00	41.33	51.67	62.00
1600	21.33	32.00	42.67	53.33	64.00
1650	22.00	33.00	44.00	55.00	66.00
1700	22.67	34.00	45.33	56.67	68.00
1750	23.33	35.00	46.67	58.33	70.00
1800	24.00	36.00	48.00	60.00	72.00
1850	24.67	37.00	49.33	61.67	74.00
1900	25.33	38.00	50.67	63.33	76.00
1950	26.00	39.00	52.00	65.00	78.00
2000	26.67	40.00	53.33	66.67	80.00

## VEGETABLE AND FRUIT COLD STORAGE CHART FOR REACH-IN UNITS

number of meals served between deliveries	storage per 0.020 Cu. Ft. per meal per number meals served	storage per 0.025 Cu. Ft. per meal per number meals served	storage per 0.030 Cu. Ft. per meal per number meals served	storage per 0.035 Cu. Ft. per meal per number meals served	storage per 0.040 Cu. Ft. per meal per number meals served
200	5.33	6.67	8.00	9.33	10.67
250	6.67	8.33	10.00	11.67	13.33
300	8.00	10.00	12.00	14.00	16.00
350	9.33	11.67	14.00	16.33	18.67
400	10.67	13.33	16.00	18.67	21.33
450	12.00	15.00	18.00	21.00	24.00
500	13.33	16.67	20.00	23.33	26.67
550	14.67	18.33	22.00	25.67	29.33
600	16.00	20.00	24.00	28.00	32.00
650	17.33	21.67	26.00	30.33	34.67
700	18.67	23.33	28.00	32.67	37.33
750	20.00	25.00	30.00	35.00	40.00
800	21.33	26.67	32.00	37.33	42.67
850	22.67	28.33	34.00	39.67	45.33
900	24.00	30.00	36.00	42.00	48.00
950	25.33	31.67	38.00	44.33	50.67
1000	26.67	33.33	40.00	46.67	53.33
1050	28.00	35.00	42.00	49.00	56.00
1100	29.33	36.67	44.00	51.33	58.67
1150	30.67	38.33	46.00	53.67	61.33
1200	32.00	40.00	48.00	56.00	64.00
1250	33.33	41.67	50.00	58.33	66.67
1300	34.67	43.33	52.00	60.67	69.33
1350	36.00	45.00	54.00	63.00	72.00
1400	37.33	46.67	56.00	65.33	74.67
1450	38.67	48.33	58.00	67.67	77.33
1500	40.00	50.00	60.00	70.00	80.00
1550	41.33	51.67	62.00	72.33	82.67
1600	42.67	53.33	64.00	74.67	85.33
1650	44.00	55.00	66.00	77.00	88.00
1700	45.33	56.67	68.00	79.33	90.67
1750	46.67	58.33	70.00	81.67	93.33
1800	48.00	60.00	72.00	84.00	96.00
1850	49.33	61.67	74.00	86.33	98.67
1900	50.67	63.33	76.00	88.67	101.33
1950	52.00	65.00	78.00	91.00	104.00
2000	53.33	66.67	80.00	93.33	106.67

## DAIRY COLD STORAGE CHART FOR REACH- IN UNITS

number of meals served between deliveries	storage per 0.007 Cu. Ft. per meal per number meals served	storage per 0.009 Cu. Ft. per meal per number meals served	storage per 0.011 Cu. Ft. per meal per number meals served	storage per 0.013 Cu. Ft. per meal per number meals served	storage per 0.015 Cu. Ft. per meal per number meals served
200	1.87	2.40	2.93	3.47	4.00
250	2.33	3.00	3.67	4.33	5.00
300	2.80	3.60	4.40	5.20	6.00
350	3.27	4.20	5.13	6.07	7.00
400	3.73	4.80	5.87	6.93	8.00
450	4.20	5.40	6.60	7.80	9.00
500	4.67	6.00	7.33	8.67	10.00
550	5.13	6.60	8.07	9.53	11.00
600	5.60	7.20	8.80	10.40	12.00
650	6.07	7.80	9.53	11.27	13.00
700	6.53	8.40	10.27	12.13	14.00
750	7.00	9.00	11.00	13.00	15.00
800	7.47	9.60	11.73	13.87	16.00
850	7.93	10.20	12.47	14.73	17.00
900	8.40	10.80	13.20	15.60	18.00
950	8.87	11.40	13.93	16.47	19.00
1000	9.33	12.00	14.67	17.33	20.00
1050	9.80	12.60	15.40	18.20	21.00
1100	10.27	13.20	16.13	19.07	22.00
1150	10.73	13.80	16.87	19.93	23.00
1200	11.20	14.40	17.60	20.80	24.00
1250	11.67	15.00	18.33	21.67	25.00
1300	12.13	15.60	19.07	22.53	26.00
1350	12.60	16.20	19.80	23.40	27.00
1400	13.07	16.80	20.53	24.27	28.00
1450	13.53	17.40	21.27	25.13	29.00
1500	14.00	18.00	22.00	26.00	30.00
1550	14.47	18.60	22.73	26.87	31.00
1600	14.93	19.20	23.47	27.73	32.00
1650	15.40	19.80	24.20	28.60	33.00
1700	15.87	20.40	24.93	29.47	34.00
1750	16.33	21.00	25.67	30.33	35.00
1800	16.80	21.60	26.40	31.20	36.00
1850	17.27	22.20	27.13	32.07	37.00
1900	17.73	22.80	27.87	32.93	38.00
1950	18.20	23.40	28.60	33.80	39.00
2000	18.67	24.00	29.33	34.67	40.00

For additional formulas and information, other references to refer to include:  
 North American Association of Food Equipment Manufacturers. An Introduction to the Food Service Industry. First Edition, 1995

Salvato Textbook. Environmental Engineering & Sanitation 4<sup>th</sup> Edition. John Wiley & Sons, Inc. United States, 1992.

Kramer Engineering Data, Catalog No. R-114, Kramer-Trenton Co., Trenton, N.J.

## **PART 3 - FACILITIES TO PROTECT FOOD**

Adequate facilities must be provided to promote good hygienic practices, sanitary food handling and to minimize the potential of cross contamination between ready-to-eat and raw products.

### **GENERAL FOOD PROTECTION**

Provide a separate food preparation area for handling, washing and preparing raw meat, fish, and poultry, if served. Where portable cutting boards are planned, they should be color coded or labeled for specific use.

All food being displayed, served, or held must be adequately protected from contamination by the use of: packaging; serving line, storage or salad bar protector devices; display cases; or by other effective means, including dispensers.

Salad bars and sneeze guards shall comply with the standards of an ANSI accredited certification program. The food shield should intercept the direct line between the customer's mouth and the food on display. On the average, the vertical distance from the customer's mouth to the floor is 4'6" to 5'. This average must be adjusted for children in educational institutions, and for other special installations such as to accommodate the wheel chair bound. See figure #3-1 through 3-3.

Running water dipping wells should be provided for the in-use storage of dispensing utensils where frozen desserts are being portioned and dispensed.

Cleaned equipment and utensils shall be stored in a clean, dry location where they are not exposed to splash, dust, or other contamination. This should be of particular concern at salad bars and waitress stations.

### **FOOD PREPARATION SINK**

Provide separate areas to segregate food handling operations involving raw and ready-to-eat products. For washing raw fruits and vegetables, it is advisable to provide a separate food preparation sink with a minimum 18" drainboard.

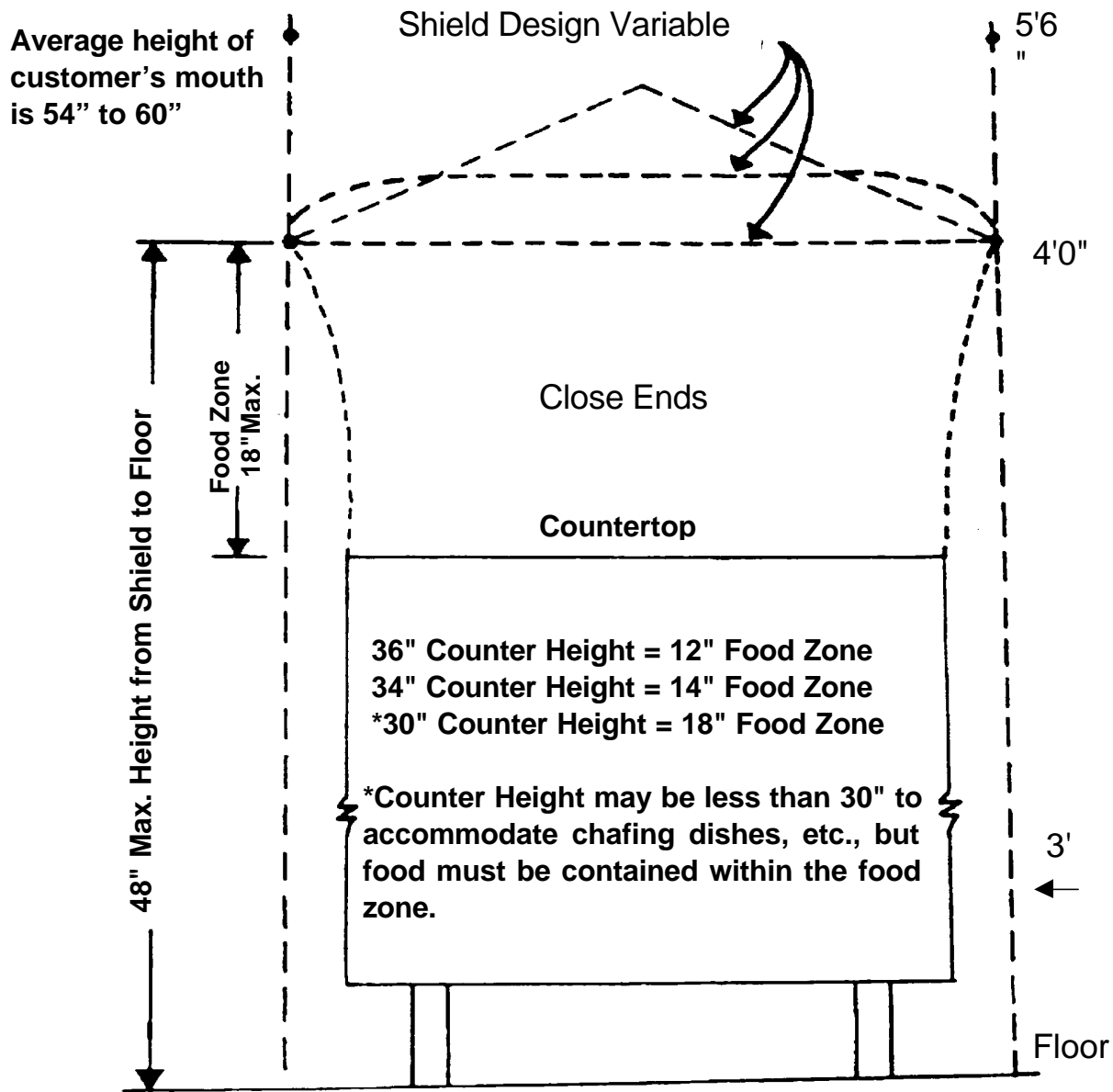

“End View”

## Buffet or Smorgasbord Shielding

Figure 3-1

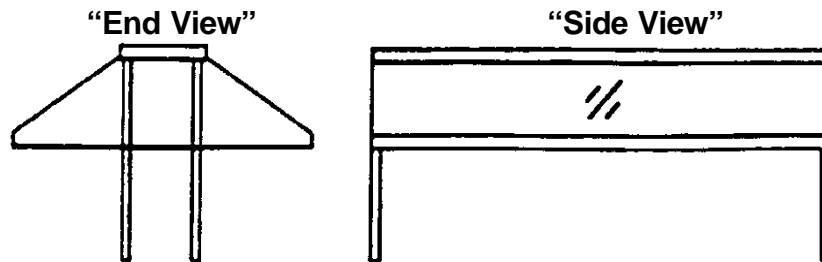

**Double Buffet Service**

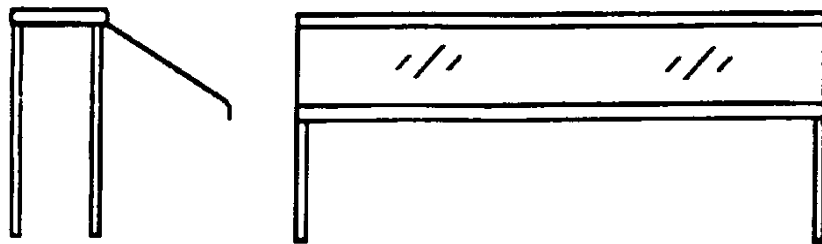

**Single Buffet Service**

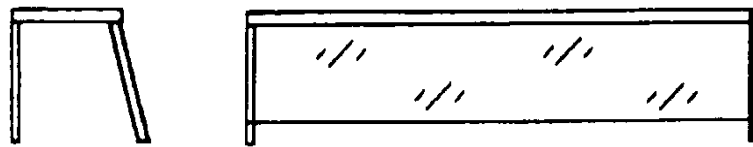

**Cafeteria Service**

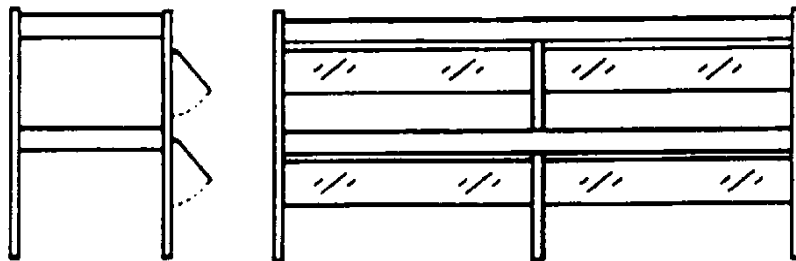

**Double Tier Cafeteria Service**

## Buffet or Smorgasbord Shielding

Figure 3-2

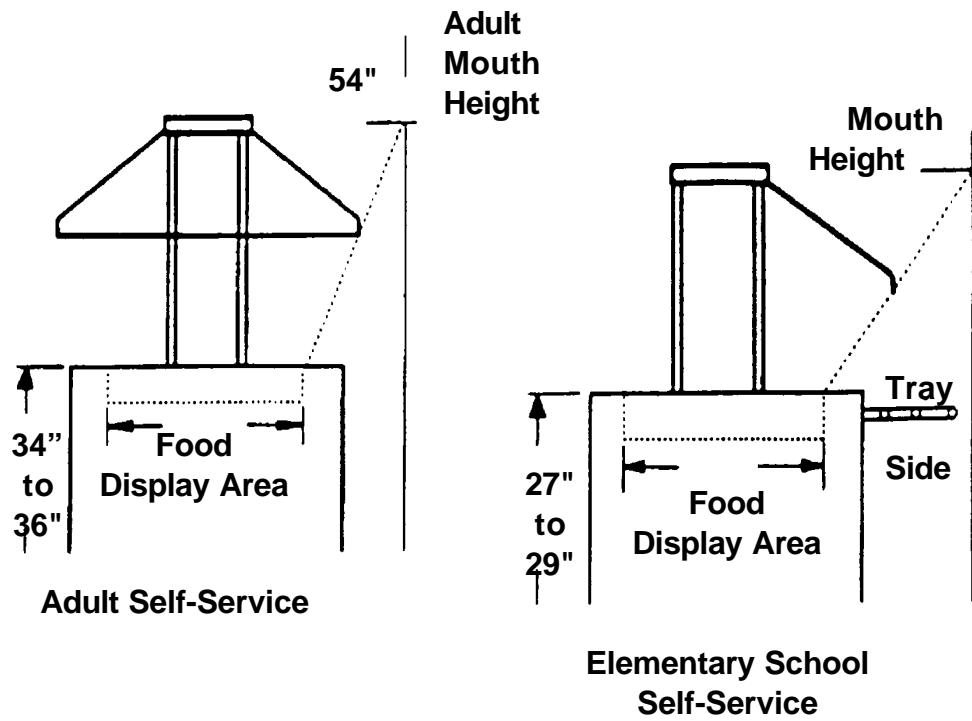

## Buffet or Smorgasbord Shielding

Figure 3-3

## **PART 4 - HANDWASHING**

### **HANDWASHING FACILITY**

Provide a separate handwashing sink; hand drying device, or disposable towels; supply of hand cleaning agent; and waste receptacle for each food preparation area, utensil washing area, and toilet room (required number based on law). Sinks used for food preparation or for washing equipment or utensils shall not be used for handwashing.

Each handwashing sink shall be provided with hot and cold water tempered by means of a mixing valve or a combination faucet to provide water at a temperature of at least 110°F. Any self-closing, slow-closing or metering faucet shall be designed to provide a flow of water for at least 15 seconds without the need to reactivate the faucet. See figure #4-1.

Handwashing sinks shall be of sufficient number and conveniently located for use by all employees in food preparation and utensil washing areas. Handwashing sinks shall be easily accessible and may not be used for purposes other than handwashing. It is suggested that a handwash sink be located within 25 feet of a work station. Splashguard protection is suggested if adequate spacing to adjoining food, food preparation, food contact surfaces, and utensil washing area surfaces (drainboards) is insufficient. Splash from a handwash sink may not contaminate food, equipment or utensils. A baffle or barrier may be needed if the handsink abuts a food preparation or service surface.

**Soap  
Dispenser  
(used only for  
hand-washing)**

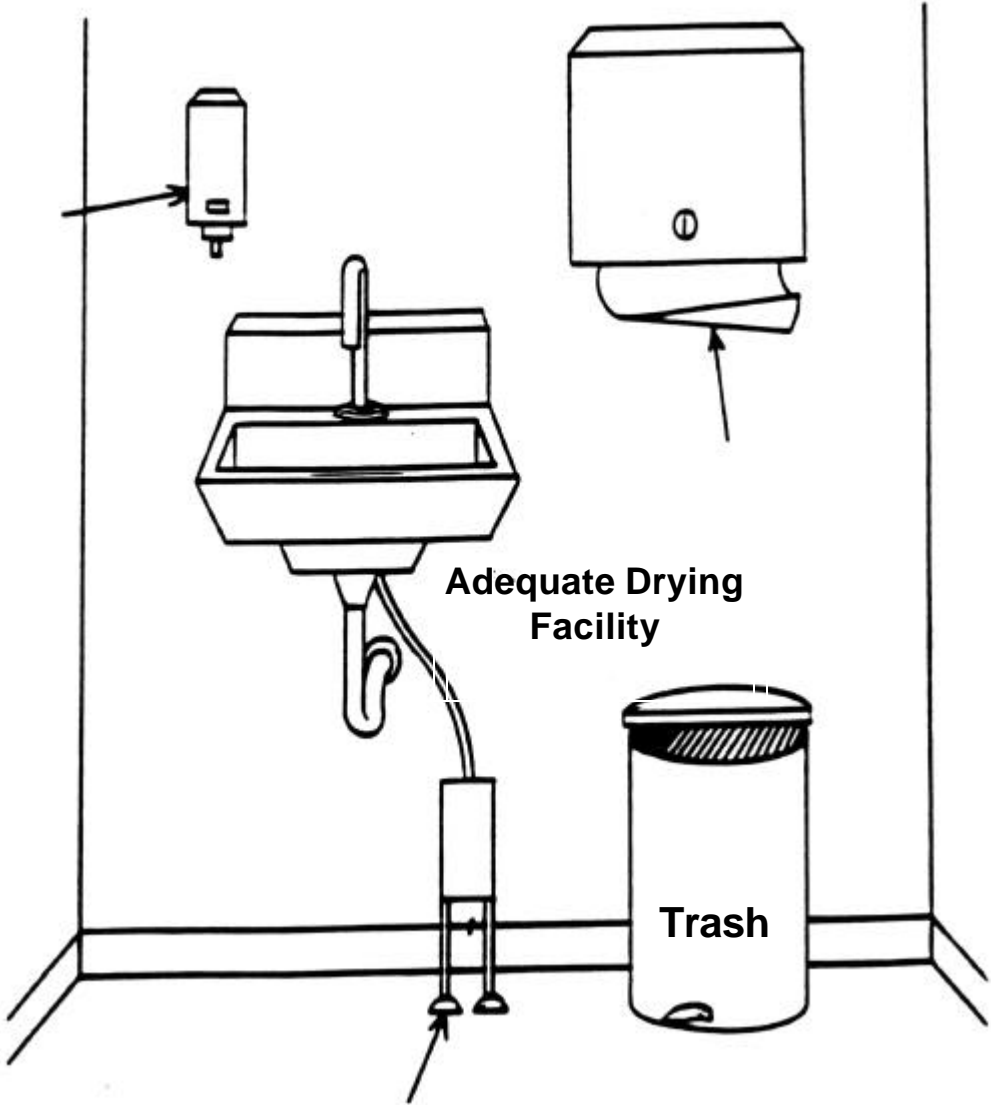

**Adequate Drying  
Facility**

**Trash**

**Handwash Sink  
Example**

**Figure 4-1**

## PART 5 - WATER SUPPLY AND SEWAGE DISPOSAL

Where non-municipal water supply and sewage disposal are utilized, the location of these facilities shall be noted on the plans and certification of compliance with state and local regulations shall be provided.

### WATER SUPPLY

Enough potable water for the needs of the food service establishment shall be provided from a source constructed and operated according to law.

Potable water from a municipal water supply is appropriate for the needs of a food service establishment.

The pumping and storage capacities, as well as the frequency of testing of a non-municipal water supply must be specified.

### WATER USE DATA GUIDE (Suggested Formula)

-Pot sink = 49.399 gals. for a total fill	
49.399 x 4 fills per day =	197.596 gals. per day
-Floor wash = 12 gals.	
12 x 3 fills per day =	36 gals. per day
-General sanitation =	30 gals. per day
-Prep sink =15 gals	
15 x 2 fills per day =	30 gals. per day
-3 Full time employees	
3 x 30 gals. =	90 gals per day
-Dishmachine	
46.2 gals x 2 meal periods=	92.4 gals. per day
<hr/>	<hr/>
Total Daily Usage =	476 gals. per day

### SEWAGE DISPOSAL

All sewage including liquid waste shall be disposed of by a public sewage system or by a sewage disposal system constructed and operated according to law. If used, a grease trap shall be located to be easily accessible for cleaning.



## **PART 6 - EQUIPMENT AND INSTALLATION**

All equipment in food establishments should be certified or classified for sanitation by an ANSI accredited certification program.

Equipment including ice makers and ice storage equipment shall not be located under exposed or unprotected sewer lines, open stairwells or other sources of contamination.

The following equipment installation requirements will help to ensure proper spacing and sealing which will allow for adequate and easy cleaning:

### **FLOOR MOUNTED EQUIPMENT**

Whenever possible equipment should be mounted on approved castors or wheels to facilitate easy moving, cleaning, and flexibility of operation. Wheeled equipment requiring utility services should be provided with easily accessible quick-disconnects or the utility service lines should be flexible and of sufficient length to permit moving the equipment for cleaning. Check with local fire safety and building codes to ensure that such installations are acceptable. See figure #6-1 thru 6-3.

Floor-mounted equipment not mounted on wheels or castors with the above utility connections should be:

1. Sealed to the floor around the entire perimeter of the equipment (the sealing compound should be pliable but not gummy or sticky, non-shrinking, retain elasticity and provide a water and vermin-tight joint); or
2. Installed on a solid, smooth, non-absorbent masonry base. Masonry bases and curbs should have a minimum height of 2" and be coved at the junction of the platform and the floor with at least a 1/4" radius. The equipment should overhang the base by at least 1" but not more than 4". Spaces between the masonry base and the equipment must be sealed; or
3. Elevated on legs to provide at least a 6" clearance between the floor and equipment. The legs shall contain no hollow open ends. See figure #6-4.
4. Display shelving units, display refrigeration units and display freezers may be exempt from the above.

For equipment not readily moveable by one person, spacing between and behind equipment must be sufficient to permit cleaning. Provide at least 6" of clear unobstructed space under each piece of equipment. See figure #6-5.

If all the equipment butts against a wall it must be joined to it and/or sealed in a manner to prevent liquid waste, dust and debris from collecting between the wall and the equipment.

When equipment is butted together or spreader plates are used the resultant joint must prevent the accumulation of spillage and debris therein and must facilitate cleaning.

Provide unobstructed and functional aisle and working spaces between units of equipment. A minimum 36" width is recommended. See figure #6-6.

All utility and service lines and openings through the floor must be sealed adequately. Exposed vertical and horizontal pipes and lines must be kept to a minimum. The installation of exposed horizontal utility lines and pipes on the floor is prohibited. Any insulation materials used on utility pipes or lines in the food preparation or dishwashing areas must be smooth, non-absorbent and easy to clean. It is desirable that switch boxes, electrical control panels, wall mounted cabinets, etc. be installed out of the cooking and dishwashing areas. Electrical units which are installed in areas subject to splash from necessary cleaning operations or food preparation should be water-tight and washable.

#### TABLE MOUNTED EQUIPMENT

All table mounted equipment shall be:

- A. Sealed to the table or counter; or
- B. Elevated on approved legs to provide at least a 4" clearance between the table or counter and equipment and installed to facilitate cleaning; or
- C. Portable: 30 pounds or less, no dimensions exceeding 36", no fixed utility connections.

Equipment open underneath, such as drain boards, dish tables, and other tables should be installed 4" away from the wall or sealed to the wall. Metal legs of all tables and sinks in food preparation areas should be made of stainless steel. The under-shelves of food preparation tables should also be made of stainless steel.

---

Other references are available for additional formulas and information. One such reference includes: North American Association of Food Equipment Manufacturers. An Introduction to the Food Service Industry. First Edition, 1995.

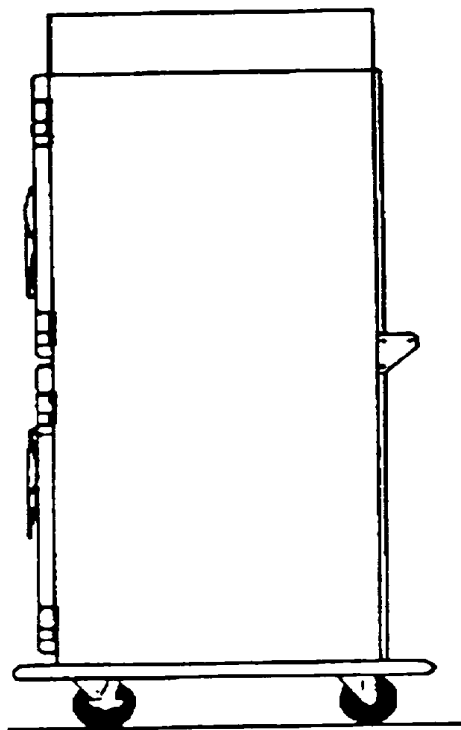

Holding Cabinet

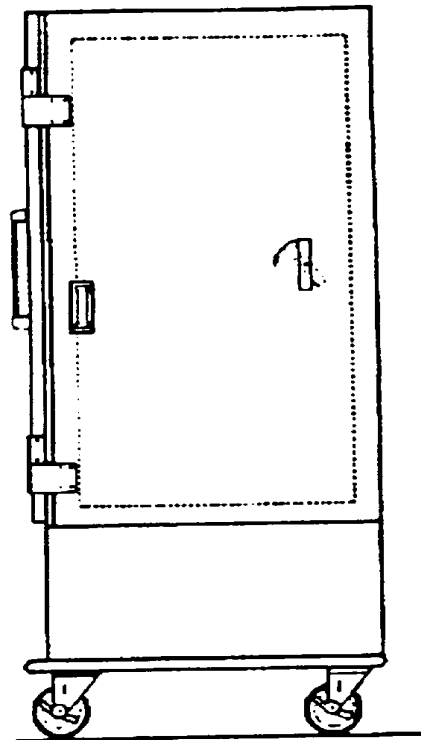

Reach-in Refrigerator

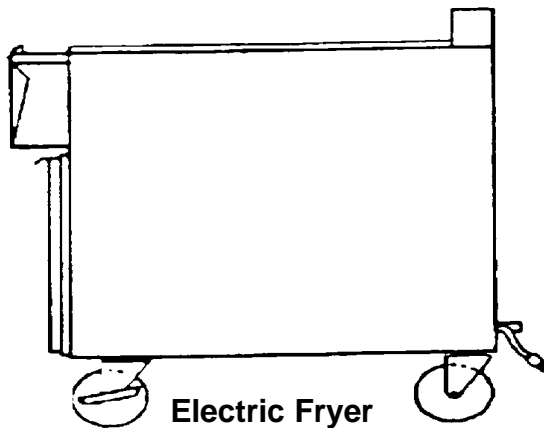

Electric Fryer

## Kitchen Equipment Mounted On Castors

Figure 6-1

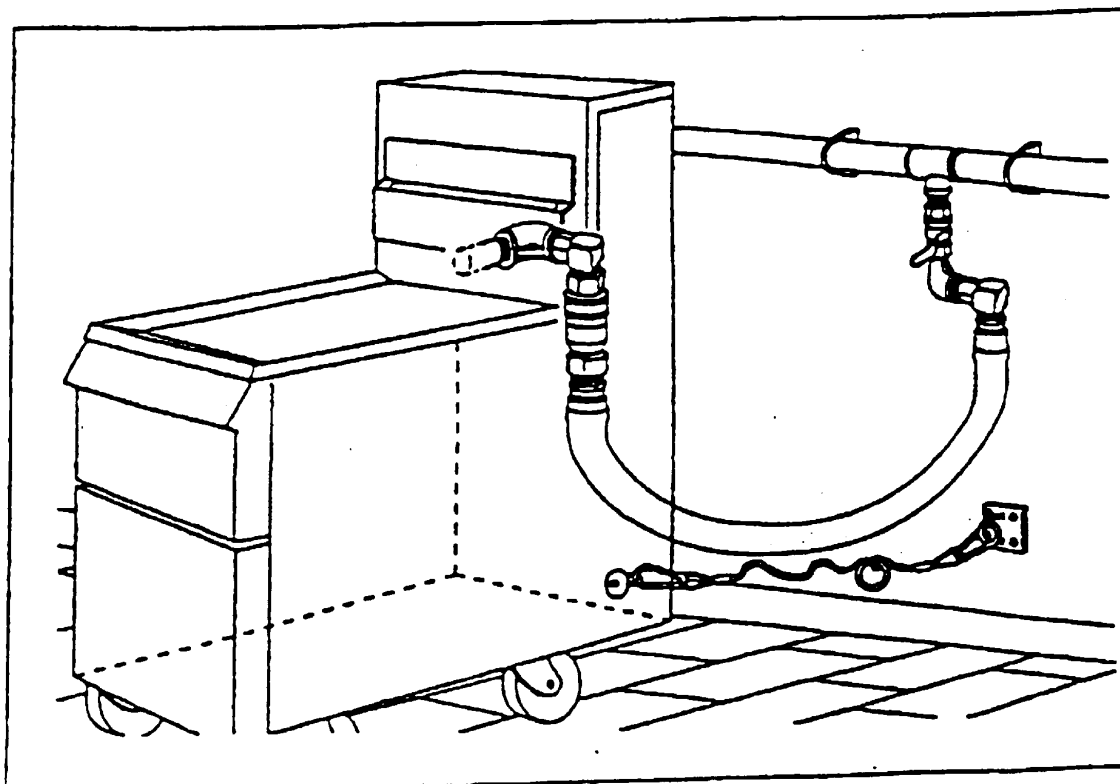

## Flexible Gas Connector With Keeper Chain

Figure 6-2

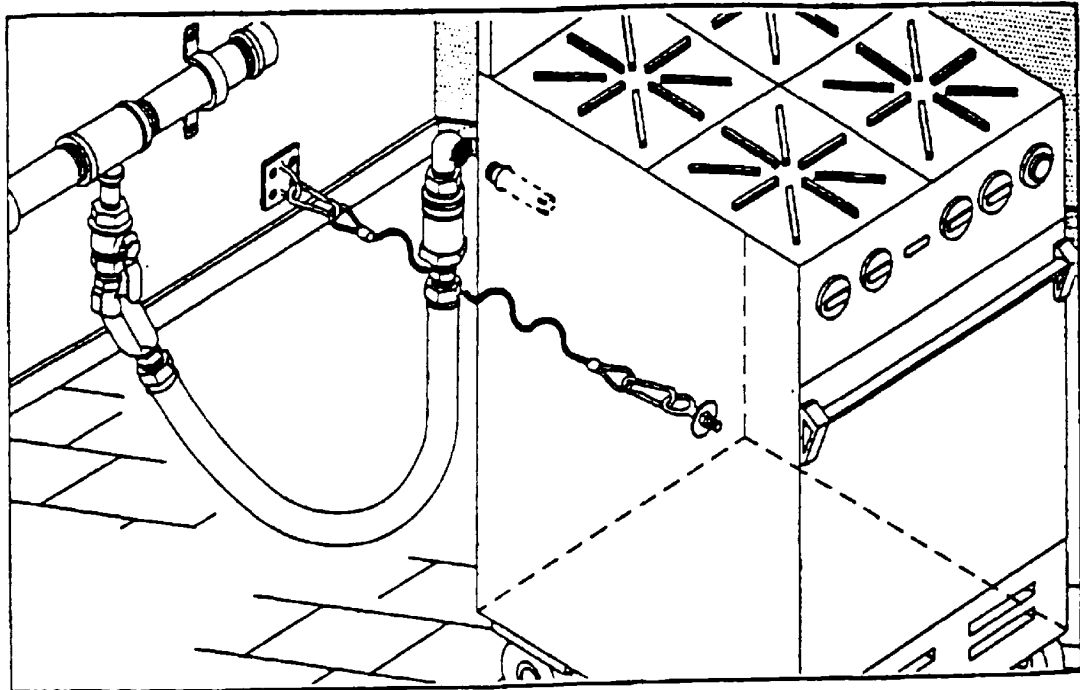

## Flexible Gas Connector With Keeper Chain

Figure 6-3

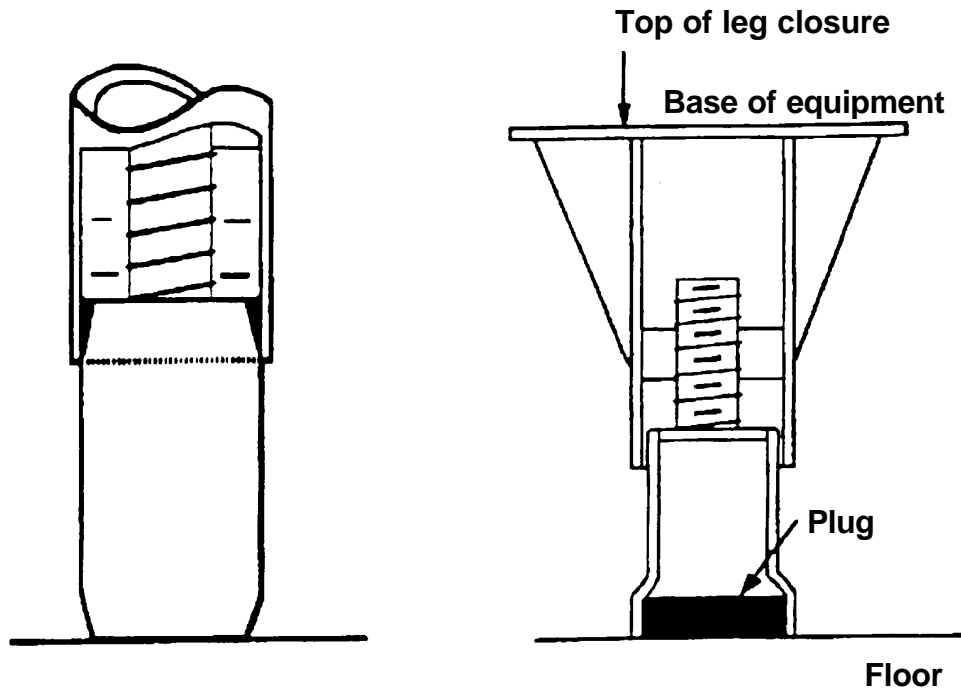

## Floor Mounted

Figure 6-4

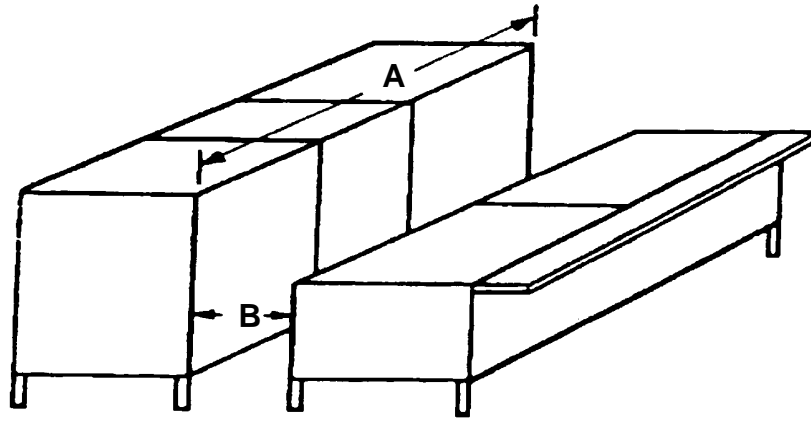

Equipment sealed together

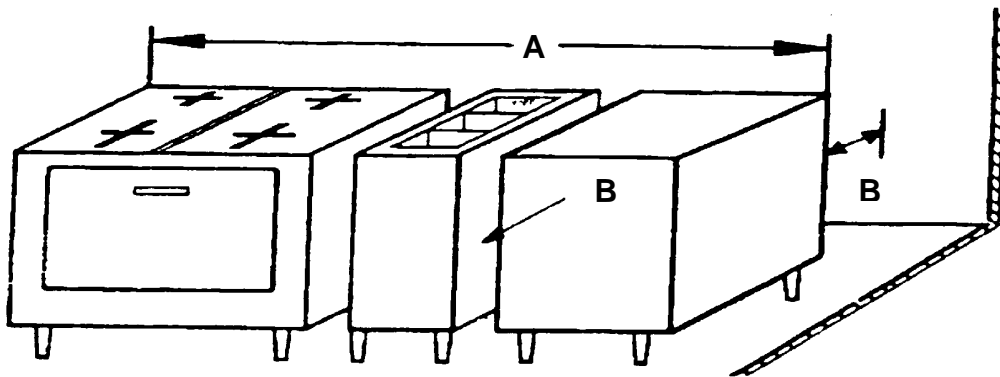

Equipment spaced apart

Recommended Equipment Spacing From Walls Provided Access is Available From Both Ends:

<u>Equipment Length (A)</u>	<u>Space From Walls and Equipment (B)</u>
4' or less	6"
4' - 8'	12"
8' or more	18"

## Equipment Spacing

Figure 6-5

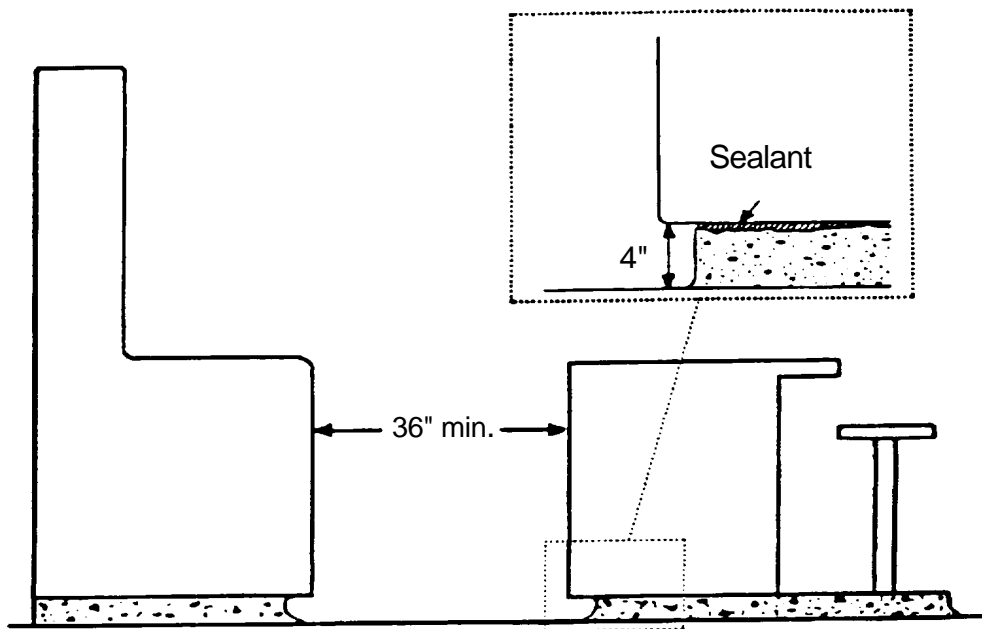

## Floor Mounted Equipment

Figure 6-6

## **PART 7 - DRY STORAGE CONSIDERATION**

The dry storage space required depends upon the menu, number of meals, quantities purchased, and frequency of delivery. The location of the storeroom should be adjacent to the food preparation area and convenient to receiving. Adequate ventilation should be provided. Ideally, the storeroom should be free of uninsulated steam and water pipes, water heaters, transformers, refrigeration condensing units, steam generators or other heat producing equipment. Temperatures of 50°F to 70°F are recommended.

A suggested formula used in estimating required storage space is as follows:

Required Storage Area

$$\text{(square feet)} = \frac{\text{Volume per meal} \times \text{Number of meals between deliveries}}{\text{Average height} \times \text{Fraction of usable storeroom floor area}}$$

- (1) Volume per meal = .025 to .050 cu. ft. per meal served
- (2) Useful storeroom height = 4 to 7 feet
- (3) Storage time between deliveries = 3 to 14 days
- (4) Fraction of useable storeroom floor area = .3 to .6

For example assume 100 meals per day and a 10 day storage between deliveries = 1000 meals for which to provide storage:

$$\text{Required Storage Area} = \frac{.05 \text{ cubic feet} \times 1000 \text{ meals}}{5 \text{ feet} \times .3}$$

Required Storage Area = 33 square feet

Shelving can be constructed of suitably finished hard wood, durable plastic or preferably of corrosion resistant metal. The highest shelf for practical use is 7' and the lowest one should be 6" from the floor. Clearance between the shelves should be at least 15". Sufficient moveable dunnage racks and dollies (with smooth surfaces, cleanable in case of food spillage or package breakage) should be provided to store all food containers at least 6" above the floor.

Dunnage racks, pallets, etc. should be spaced sufficiently from walls to allow for vermin monitoring and inspection. A space of 18" is recommended. Wooden shelving and pallets require a higher level of maintenance and are more conducive to vermin infestation. Food containers shall not be stored under exposed or unprotected sewer lines or leaking water lines. Approved food containers with tight-fitting covers and dollies should be used for storing bulk foods such as flour, cornmeal, sugar, dried beans, rice and similar foods. Scoops are needed for each food storage container in use.

## **DRY STORAGE CALCULATION EXAMPLES:**

Two suggested formulas used in estimating required storage space are as follows:

**Formula # 1** - Linear feet of shelving for storage (ft) =

$$\frac{\text{Volume per meal x number of meals between deliveries}}{D \times H \times C}$$

D = Depth of the shelves in feet

H = Clearance between shelves in feet

C = 80% effective capacity of shelf height

For example, assume 400 meals per day and a 10 day storage between deliveries = 4000 meals for which to provide storage, Volume of .035 per meal, shelf depth of 18 inches, clearance of 18 inches between shelves and 80% effective capacity of shelf height:

$$\text{Linear feet of shelving for storage (ft.)} = \frac{.035 \text{ cu. ft} \times 4000 \text{ meals}}{1.5 \text{ ft.} \times 1.5 \text{ ft.} \times 80\%} = 77.77 \text{ Linear feet}$$

**Formula # 2** – Required Storage Area (sq. ft.) =

$$\frac{\text{Volume per meal x number of meals between deliveries}}{\text{Average height x fraction of usable storeroom floor area}}$$

(1) Volume per meal = .025 to .050 cu. ft. per meal served (2) Useful storage height = 4 to 7 feet.

(2) Storage time between deliveries = 3 to 14 days

(3) Fraction of useable storeroom floor area = .3 to .6

For example, assume 100 meals per day and a 10 day storage between deliveries = 1000 meals for which to provide storage:

$$\text{Required Storage Area} = .05 \text{ cu. ft.} \times 1000 \text{ meals} \div 5 \text{ ft.} \times .3$$

$$\text{Required Storage Area} = 33 \text{ square feet}$$

Cited on the next few pages are examples of dry storage calculations prepared by the North Carolina Department of Health, Food, Lodging and Institutional Sanitation Branch.

---

Other references are available for additional formulas and information. One such reference includes: Stipanuk, D.M., & Roffmann, H., Hospitality Facilities Management & Design, 1992.

<b>Formula #1 Dry Storage Chart # 1</b>				<b>Formula #1 Dry Storage Chart # 2</b>			
calculated storage area per .025 cu. ft. per meal served Linear feet of storage shelf area need				Calculated storage area per .025 cu. ft. per meal served Linear feet of storage shelf area need			
Meals Served	1 ft. deep by 1ft high shelves	1 ft. deep by 18 inches high shelves	1 ft. deep by 2ft high shelves	Meals Served	1.5 ft. deep by 1ft high shelves	1.5 ft. deep by 18 inches high shelves	1.5 ft. deep by 2ft high shelves
200	6.25	4.17	3.13	200	4.17	2.78	2.08
250	7.81	5.21	3.91	250	5.21	3.47	2.60
300	9.38	6.25	4.69	300	6.25	4.17	3.13
350	10.94	7.29	5.47	350	7.29	4.86	3.65
400	12.50	8.33	6.25	400	8.33	5.56	4.17
450	14.06	9.38	7.03	450	9.38	6.25	4.69
500	15.63	10.42	7.81	500	10.42	6.94	5.21
550	17.19	11.46	8.59	550	11.46	7.64	5.73
600	18.75	12.50	9.38	600	12.50	8.33	6.25
650	20.31	13.54	10.16	650	13.54	9.03	6.77
700	21.88	14.58	10.94	700	14.58	9.72	7.29
750	23.44	15.63	11.72	750	15.63	10.42	7.81
800	25.00	16.67	12.50	800	16.67	11.11	8.33
850	26.56	17.71	13.28	850	17.71	11.81	8.85
900	28.13	18.75	14.06	900	18.75	12.50	9.38
950	29.69	19.79	14.84	950	19.79	13.19	9.90
1000	31.25	20.83	15.63	1000	20.83	13.89	10.42

<b>Formula #1 Dry Storage Chart # 3</b>				<b>Formula #1 Dry Storage Chart # 4</b>			
calculated storage area per .025 cu. ft. per meal served Linear feet of storage shelf area need				calculated storage area per .03 cu. ft. per meal served Linear feet of storage shelf area need			
Meals Served	2 ft. deep by 1ft high shelves	2 ft. deep by 18inches high shelves	2 ft. deep by 2ft high shelves	Meals Served	1 ft. deep by 1ft high shelves	1 ft. deep by 18 inches high shelves	1 ft. deep by 2ft high shelves
200	3.13	2.08	1.56	200	7.50	5.00	3.75
250	3.91	2.60	1.95	250	9.38	6.25	4.69
300	4.69	3.13	2.34	300	11.25	7.50	5.63
350	5.47	3.65	2.73	350	13.13	8.75	6.56
400	6.25	4.17	3.13	400	15.00	10.00	7.50
450	7.03	4.69	3.52	450	16.88	11.25	8.44
500	7.81	5.21	3.91	500	18.75	12.50	9.38
550	8.59	5.73	4.30	550	20.63	13.75	10.31
600	9.38	6.25	4.69	600	22.50	15.00	11.25
650	10.16	6.77	5.08	650	24.38	16.25	12.19
700	10.94	7.29	5.47	700	26.25	17.50	13.13
750	11.72	7.81	5.86	750	28.13	18.75	14.06
800	12.50	8.33	6.25	800	30.00	20.00	15.00
850	13.28	8.85	6.64	850	31.88	21.25	15.94
900	14.06	9.38	7.03	900	33.75	22.50	16.88
950	14.84	9.90	7.42	950	35.63	23.75	17.81
1000	15.63	10.42	7.81	1000	37.50	25.00	18.75

<b>Formula #1 Dry Storage Chart # 5</b>				<b>Formula #1 Dry Storage Chart #6</b>			
calculated storage area per .03 cu. ft. per meal served Linear feet of storage shelf area need				calculated storage area per .03 cu. ft. per meal served Linear feet of storage shelf area need			
Meals Served	1.5 ft. deep by 1ft high shelves	1.5 ft. deep by 18 inches high shelves	1.5 ft. deep by 2ft high shelves	Meals Served	2 ft. deep by 1ft high shelves	2 ft. deep by 18inches high shelves	2 ft. deep by 2ft high shelves
200	5.00	3.33	2.50	200	3.75	2.50	1.88
250	6.25	4.17	3.13	250	4.69	3.13	2.34
300	7.50	5.00	3.75	300	5.63	3.75	2.81
350	8.75	5.83	4.38	350	6.56	4.38	3.28
400	10.00	6.67	5.00	400	7.50	5.00	3.75
450	11.25	7.50	5.63	450	8.44	5.63	4.22
500	12.50	8.33	6.25	500	9.38	6.25	4.69
550	13.75	9.17	6.88	550	10.31	6.88	5.16
600	15.00	10.00	7.50	600	11.25	7.50	5.63
650	16.25	10.83	8.13	650	12.19	8.13	6.09
700	17.50	11.67	8.75	700	13.13	8.75	6.56
750	18.75	12.50	9.38	750	14.06	9.38	7.03
800	20.00	13.33	10.00	800	15.00	10.00	7.50
850	21.25	14.17	10.63	850	15.94	10.63	7.97
900	22.50	15.00	11.25	900	16.88	11.25	8.44
950	23.75	15.83	11.88	950	17.81	11.88	8.91
1000	25.00	16.67	12.50	1000	18.75	12.50	9.38

<b>Formula #1 Dry Storage Chart # 7</b>				<b>Formula #1 Dry Storage Chart # 8</b>			
calculated storage area per .035 cu. ft. per meal served Linear feet of storage shelf area need				calculated storage area per .035 cu. ft. per meal served Linear feet of storage shelf area need			
Meals Served	1 ft. deep by 1ft high shelves	1 ft. deep by 18 inches high shelves	1 ft. deep by 2ft high shelves	Meals Served	1.5 ft. deep by 1ft high shelves	1.5 ft. deep by 18 inches high shelves	1.5 ft. deep by 2ft high shelves
200	8.75	5.83	4.38	200	5.83	3.89	2.92
250	10.94	7.29	5.47	250	7.29	4.86	3.65
300	13.13	8.75	6.56	300	8.75	5.83	4.38
350	15.31	10.21	7.66	350	10.21	6.81	5.10
400	17.50	11.67	8.75	400	11.67	7.78	5.83
450	19.69	13.13	9.84	450	13.13	8.75	6.56
500	21.88	14.58	10.94	500	14.58	9.72	7.29
550	24.06	16.04	12.03	550	16.04	10.69	8.02
600	26.25	17.50	13.13	600	17.50	11.67	8.75
650	28.44	18.96	14.22	650	18.96	12.64	9.48
700	30.63	20.42	15.31	700	20.42	13.61	10.21
750	32.81	21.88	16.41	750	21.88	14.58	10.94
800	35.00	23.33	17.50	800	23.33	15.56	11.67
850	37.19	24.79	18.59	850	24.79	16.53	12.40
900	39.38	26.25	19.69	900	26.25	17.50	13.13
950	41.56	27.71	20.78	950	27.71	18.47	13.85
1000	43.75	29.17	21.88	1000	29.17	19.44	14.58

<b>Formula #1 Dry Storage Chart # 9</b>				<b>Formula #1 Dry Storage Chart # 10</b>			
calculated storage area per .035 cu. ft. per meal served Linear feet of storage shelf area need				calculated storage area per .04 cu. ft. per meal served Linear feet of storage shelf area need			
Meals Served	2 ft. deep by 1ft high shelves	2 ft. deep by 18inches high shelves	2 ft. deep by 2ft high shelves	Meals Served	1 ft. deep by 1ft high shelves	1 ft. deep by 18 inches high shelves	1 ft. deep by 2ft high shelves
200	4.38	2.92	2.19	200	10.00	6.67	5.00
250	5.47	3.65	2.73	250	12.50	8.33	6.25
300	6.56	4.38	3.28	300	15.00	10.00	7.50
350	7.66	5.10	3.83	350	17.50	11.67	8.75
400	8.75	5.83	4.38	400	20.00	13.33	10.00
450	9.84	6.56	4.92	450	22.50	15.00	11.25
500	10.94	7.29	5.47	500	25.00	16.67	12.50
550	12.03	8.02	6.02	550	27.50	18.33	13.75
600	13.13	8.75	6.56	600	30.00	20.00	15.00
650	14.22	9.48	7.11	650	32.50	21.67	16.25
700	15.31	10.21	7.66	700	35.00	23.33	17.50
750	16.41	10.94	8.20	750	37.50	25.00	18.75
800	17.50	11.67	8.75	800	40.00	26.67	20.00
850	18.59	12.40	9.30	850	42.50	28.33	21.25
900	19.69	13.13	9.84	900	45.00	30.00	22.50
950	20.78	13.85	10.39	950	47.50	31.67	23.75
1000	21.88	14.58	10.94	1000	50.00	33.33	25.00

<b>Formula #1 Dry Storage Chart # 11</b>				<b>Formula #1 Dry Storage Chart # 12</b>			
calculated storage area per .04 cu. ft. per meal served Linear feet of storage shelf area need				calculated storage area per .04 cu. ft. per meal served Linear feet of storage shelf area need			
Meals Served	1.5 ft. deep by 1ft high shelves	1.5 ft. deep by 18 inches high shelves	1.5 ft. deep by 2ft high shelves	Meals Served	2 ft. deep by 1ft high shelves	2 ft. deep by 18inches high shelves	2 ft. deep by 2ft high shelves
200	6.67	4.44	3.33	200	5.00	3.33	2.50
250	8.33	5.56	4.17	250	6.25	4.17	3.13
300	10.00	6.67	5.00	300	7.50	5.00	3.75
350	11.67	7.78	5.83	350	8.75	5.83	4.38
400	13.33	8.89	6.67	400	10.00	6.67	5.00
450	15.00	10.00	7.50	450	11.25	7.50	5.63
500	16.67	11.11	8.33	500	12.50	8.33	6.25
550	18.33	12.22	9.17	550	13.75	9.17	6.88
600	20.00	13.33	10.00	600	15.00	10.00	7.50
650	21.67	14.44	10.83	650	16.25	10.83	8.13
700	23.33	15.56	11.67	700	17.50	11.67	8.75
750	25.00	16.67	12.50	750	18.75	12.50	9.38
800	26.67	17.78	13.33	800	20.00	13.33	10.00
850	28.33	18.89	14.17	850	21.25	14.17	10.63
900	30.00	20.00	15.00	900	22.50	15.00	11.25
950	31.67	21.11	15.83	950	23.75	15.83	11.88
1000	33.33	22.22	16.67	1000	25.00	16.67	12.50

<b>Formula #1 Dry Storage Chart # 13</b>				<b>Formula #1 Dry Storage Chart # 14</b>			
calculated storage area per .045 cu. ft. per meal served Linear feet of storage shelf area need				calculated storage area per .045 cu. ft. per meal served Linear feet of storage shelf area need			
Meals Served	1 ft. deep by 1ft high shelves	1 ft. deep by 18 inches high shelves	1 ft. deep by 2ft high shelves	Meals Served	1.5 ft. deep by 1ft high shelves	1.5 ft. deep by 18 inches high shelves	1.5 ft. deep by 2ft high shelves
200	11.25	7.50	5.63	200	7.50	5.00	3.75
250	14.06	9.38	7.03	250	9.38	6.25	4.69
300	16.88	11.25	8.44	300	11.25	7.50	5.63
350	19.69	13.13	9.84	350	13.13	8.75	6.56
400	22.50	15.00	11.25	400	15.00	10.00	7.50
450	25.31	16.88	12.66	450	16.88	11.25	8.44
500	28.13	18.75	14.06	500	18.75	12.50	9.38
550	30.94	20.63	15.47	550	20.63	13.75	10.31
600	33.75	22.50	16.88	600	22.50	15.00	11.25
650	36.56	24.38	18.28	650	24.38	16.25	12.19
700	39.38	26.25	19.69	700	26.25	17.50	13.13
750	42.19	28.13	21.09	750	28.13	18.75	14.06
800	45.00	30.00	22.50	800	30.00	20.00	15.00
850	47.81	31.88	23.91	850	31.88	21.25	15.94
900	50.63	33.75	25.31	900	33.75	22.50	16.88
950	53.44	35.63	26.72	950	35.63	23.75	17.81
1000	56.25	37.50	28.13	1000	37.50	25.00	18.75

<b>Formula #1 Dry Storage Chart # 15</b>				<b>Formula #1 Dry Storage Chart # 16</b>			
calculated storage area per .045 cu. ft. per meal served Linear feet of storage shelf area need				Calculated storage area per .05 cu. ft. per meal served Linear feet of storage shelf area need			
Meals Served	2 ft. deep by 1ft high shelves	2 ft. deep by 18 inches high shelves	2 ft. deep by 2ft high shelves	Meals Served	1 ft. deep by 1ft high shelves	1 ft. deep by 18 inches high shelves	1 ft. deep by 2ft high shelves
200	5.63	3.75	2.81	200	12.50	8.33	6.25
250	7.03	4.69	3.52	250	15.63	10.42	7.81
300	8.44	5.63	4.22	300	18.75	12.50	9.38
350	9.84	6.56	4.92	350	21.88	14.58	10.94
400	11.25	7.50	5.63	400	25.00	16.67	12.50
450	12.66	8.44	6.33	450	28.13	18.75	14.06
500	14.06	9.38	7.03	500	31.25	20.83	15.63
550	15.47	10.31	7.73	550	34.38	22.92	17.19
600	16.88	11.25	8.44	600	37.50	25.00	18.75
650	18.28	12.19	9.14	650	40.63	27.08	20.31
700	19.69	13.13	9.84	700	43.75	29.17	21.88
750	21.09	14.06	10.55	750	46.88	31.25	23.44
800	22.50	15.00	11.25	800	50.00	33.33	25.00
850	23.91	15.94	11.95	850	53.13	35.42	26.56
900	25.31	16.88	12.66	900	56.25	37.50	28.13
950	26.72	17.81	13.36	950	59.38	39.58	29.69
1000	28.13	18.75	14.06	1000	62.50	41.67	31.25

<b>Formula #1 Dry Storage Chart # 17</b>				<b>Formula #1 Dry Storage Chart # 18</b>			
calculated storage area per .05 cu. ft. per meal served Linear feet of storage shelf area need				Calculated storage area per .05 cu. ft. per meal served Linear feet of storage shelf area need			
Meals Served	1.5 ft. deep by 1ft high shelves	1.5 ft. deep by 18 inches high shelves	1.5 ft. deep by 2ft high shelves	Meals Served	2 ft. deep by 1ft high shelves	2 ft. deep by 18inches high shelves	2 ft. deep by 2ft high shelves
200	8.33	5.56	4.17	200	6.25	4.17	3.13
250	10.42	6.94	5.21	250	7.81	5.21	3.91
300	12.50	8.33	6.25	300	9.38	6.25	4.69
350	14.58	9.72	7.29	350	10.94	7.29	5.47
400	16.67	11.11	8.33	400	12.50	8.33	6.25
450	18.75	12.50	9.38	450	14.06	9.38	7.03
500	20.83	13.89	10.42	500	15.63	10.42	7.81
550	22.92	15.28	11.46	550	17.19	11.46	8.59
600	25.00	16.67	12.50	600	18.75	12.50	9.38
650	27.08	18.06	13.54	650	20.31	13.54	10.16
700	29.17	19.44	14.58	700	21.88	14.58	10.94
750	31.25	20.83	15.63	750	23.44	15.63	11.72
800	33.33	22.22	16.67	800	25.00	16.67	12.50
850	35.42	23.61	17.71	850	26.56	17.71	13.28
900	37.50	25.00	18.75	900	28.13	18.75	14.06
950	39.58	26.39	19.79	950	29.69	19.79	14.84
1000	41.67	27.78	20.83	1000	31.25	20.83	15.63

## Dry Storage Chart # 1 - Formula #2

calculated storage area per .025 cu. ft. per meal served						calculated storage area per .03 cu. ft. per meal served					
meals served	useful storeroom height	0.3 usable storeroom floor area	0.4 usable storeroom floor area	0.5 usable storeroom floor area	0.6 usable storeroom floor area	meals served	useful storeroom height	0.3 usable storeroom floor area	0.4 usable storeroom floor area	0.5 usable storeroom floor area	0.6 usable storeroom floor area
200	4	4.17	3.13	2.50	2.08	200	4	5.00	3.75	3.00	2.50
250	4	5.21	3.91	3.13	2.60	250	4	6.25	4.69	3.75	3.13
300	4	6.25	4.69	3.75	3.13	300	4	7.50	5.63	4.50	3.75
350	4	7.29	5.47	4.38	3.65	350	4	8.75	6.56	5.25	4.38
400	4	8.33	6.25	5.00	4.17	400	4	10.00	7.50	6.00	5.00
450	4	9.38	7.03	5.63	4.69	450	4	11.25	8.44	6.75	5.63
500	4	10.42	7.81	6.25	5.21	500	4	12.50	9.38	7.50	6.25
550	4	11.46	8.59	6.88	5.73	550	4	13.75	10.31	8.25	6.88
600	4	12.50	9.38	7.50	6.25	600	4	15.00	11.25	9.00	7.50
650	4	13.54	10.16	8.13	6.77	650	4	16.25	12.19	9.75	8.13
700	4	14.58	10.94	8.75	7.29	700	4	17.50	13.13	10.50	8.75
750	4	15.63	11.72	9.38	7.81	750	4	18.75	12.00	11.25	9.38
800	4	16.67	12.50	10.00	8.33	800	4	20.00	15.00	12.00	10.00
850	4	17.71	13.28	10.63	8.85	850	4	21.25	15.94	12.75	10.63
900	4	18.75	14.06	11.25	9.38	900	4	22.50	16.88	13.50	11.25
950	4	19.79	14.84	11.88	9.90	950	4	23.75	17.81	14.25	11.88
1000	4	20.83	15.63	12.50	10.42	1000	4	25.00	18.75	15.00	12.50

## Dry Storage Chart # 2 - Formula #2

calculated storage area per .04 cu. ft. per meal served						calculated storage area per .04 cu. ft. per meal served					
meals served	useful storeroom height	0.3 usable storeroom floor area	0.4 usable storeroom floor area	0.5 usable storeroom floor area	0.6 usable storeroom floor area	meals served	useful storeroom height	0.3 usable storeroom floor area	0.4 usable storeroom floor area	0.5 usable storeroom floor area	0.6 usable storeroom floor area
200	4	5.83	4.38	3.50	2.92	200	4	6.67	5.00	4.00	3.33
250	4	7.29	5.47	4.38	3.65	250	4	8.33	6.25	5.00	4.17
300	4	8.75	6.56	5.25	4.38	300	4	10.00	7.50	6.00	5.00
350	4	10.21	7.66	6.13	5.10	350	4	11.67	8.75	7.00	5.83
400	4	11.67	8.75	7.00	5.83	400	4	13.33	10.00	8.00	6.67
450	4	13.13	9.84	7.88	6.56	450	4	15.00	11.25	9.00	7.50
500	4	14.58	10.94	8.75	7.29	500	4	16.67	12.50	10.00	8.33
550	4	16.04	12.03	9.63	8.02	550	4	18.33	13.75	11.00	9.17
600	4	17.50	13.13	10.50	8.75	600	4	20.00	15.00	12.00	10.00
650	4	18.96	14.22	11.38	9.48	650	4	21.67	16.25	13.00	10.83
700	4	20.42	15.31	12.25	10.21	700	4	23.33	17.50	14.00	11.67
750	4	21.88	16.41	13.13	10.94	750	4	25.00	18.75	15.00	12.50
800	4	23.33	17.50	14.00	11.67	800	4	26.67	20.00	16.00	13.33
850	4	24.79	18.59	14.88	12.40	850	4	28.33	21.25	17.00	14.17
900	4	26.25	19.69	15.75	13.13	900	4	30.00	22.50	18.00	15.00
950	4	27.71	20.78	16.63	13.85	950	4	31.67	23.75	19.00	15.83
1000	4	29.17	21.88	17.50	14.58	1000	4	33.33	25.00	20.00	16.67

### Dry Storage Chart # 3 - Formula #2

calculated storage area per .045 cu. ft. per meal served						calculated storage area per .05 cu. ft. per meal served					
meals served	useful storeroom height	0.3 usable storeroom floor area	0.4 usable storeroom floor area	0.5 usable storeroom floor area	0.6 usable storeroom floor area	meals served	useful storeroom height	0.3 usable storeroom floor area	0.4 usable storeroom floor area	0.5 usable storeroom floor area	0.6 usable storeroom floor area
200	4	7.50	5.63	4.50	3.75	200	4	8.33	6.25	5.00	4.17
250	4	9.38	7.03	5.63	4.69	250	4	10.42	7.81	6.25	5.21
300	4	11.25	8.44	6.75	5.63	300	4	12.50	9.38	7.50	6.25
350	4	13.13	9.84	7.88	6.56	350	4	14.58	10.94	8.75	7.29
400	4	15.00	11.25	9.00	7.50	400	4	16.67	12.50	10.00	8.33
450	4	16.88	12.66	10.13	8.44	450	4	18.75	14.06	11.25	9.38
500	4	18.75	14.06	11.25	9.38	500	4	20.83	15.63	12.50	10.42
550	4	20.63	15.47	12.38	10.31	550	4	22.92	17.19	13.75	11.46
600	4	22.50	16.88	13.50	11.25	600	4	25.00	18.75	15.00	12.50
650	4	24.38	18.28	14.63	12.19	650	4	27.08	20.31	16.25	13.54
700	4	26.25	19.69	15.75	13.13	700	4	29.17	21.88	17.50	14.58
750	4	28.13	21.09	16.88	14.06	750	4	31.25	23.44	18.75	15.63
800	4	30.00	22.50	18.00	15.00	800	4	33.33	25.00	20.00	16.67
850	4	31.88	23.91	19.13	15.94	850	4	35.42	26.56	21.25	17.71
900	4	33.75	25.31	20.25	16.88	900	4	37.50	28.13	22.50	18.75
950	4	35.63	26.72	21.38	17.81	950	4	39.58	29.69	23.75	19.79
1000	4	37.50	28.13	22.50	18.75	1000	4	41.67	31.25	25.00	20.83

## Dry Storage Chart # 4 - Formula #2

calculated storage area per .025 cu. ft. per meal served						calculated storage area per .03 cu. ft. per meal served					
meals served	useful storeroom height	0.3 usable storeroom floor area	0.4 usable storeroom floor area	0.5 usable storeroom floor area	0.6 usable storeroom floor area	meals served	useful storeroom height	0.3 usable storeroom floor area	0.4 usable storeroom floor area	0.5 usable storeroom floor area	0.6 usable storeroom floor area
200	5	3.33	2.50	2.00	1.67	200	5	4.00	3.00	2.40	2.00
250	5	4.17	3.13	2.50	2.08	250	5	5.00	3.75	3.00	2.50
300	5	5.00	3.75	3.00	2.50	300	5	6.00	4.50	3.60	3.00
350	5	5.83	4.38	3.50	2.92	350	5	7.00	5.25	4.20	3.50
400	5	6.67	5.00	4.00	3.33	400	5	8.00	6.00	4.80	4.00
450	5	7.50	5.63	4.50	3.75	450	5	9.00	6.75	5.40	4.50
500	5	8.33	6.25	5.00	4.17	500	5	10.00	7.50	6.00	5.00
550	5	9.17	6.88	5.50	4.58	550	5	11.00	8.25	6.60	5.50
600	5	10.00	7.50	6.00	5.00	600	5	12.00	9.00	7.20	6.00
650	5	10.83	8.13	6.50	5.42	650	5	13.00	9.75	7.80	6.50
700	5	11.67	8.75	7.00	5.83	700	5	14.00	10.50	8.40	7.00
750	5	12.50	9.38	7.50	6.25	750	5	15.00	11.25	9.00	7.50
800	5	13.33	10.00	8.00	6.67	800	5	16.00	12.00	9.60	8.00
850	5	14.17	10.63	8.50	7.08	850	5	17.00	12.75	10.20	8.50
900	5	15.00	11.25	9.00	7.50	900	5	18.00	13.50	10.80	9.00
950	5	15.83	11.88	9.50	7.92	950	5	19.00	14.25	11.40	9.50
1000	5	16.67	12.50	10.00	8.33	1000	5	20.00	15.00	12.00	10.00

## Dry Storage Chart # 5 - Formula #2

calculated storage area per .035 cu. ft. per meal served						calculated storage area per .04 cu. ft. per meal served					
meals served	useful storeroom height	0.3 usable storeroom floor area	0.4 usable storeroom floor area	0.5 usable storeroom floor area	0.6 usable storeroom floor area	meals served	useful storeroom height	0.3 usable storeroom floor area	0.4 usable storeroom floor area	0.5 usable storeroom floor area	0.6 usable storeroom floor area
200	5	4.67	3.50	2.80	2.33	200	5	5.33	4.00	3.20	2.67
250	5	5.83	4.38	3.50	2.92	250	5	6.67	5.00	4.00	3.33
300	5	7.00	5.25	4.20	3.50	300	5	8.00	6.00	4.80	4.00
350	5	8.17	6.13	4.90	4.08	350	5	9.33	7.00	5.60	4.67
400	5	9.33	7.00	5.60	4.67	400	5	10.67	8.00	6.40	5.33
450	5	10.50	7.88	6.30	5.25	450	5	12.00	9.00	7.20	6.00
500	5	11.67	8.75	7.00	5.83	500	5	13.33	10.00	8.00	6.67
550	5	12.83	9.63	7.70	6.42	550	5	14.67	11.00	8.80	7.33
600	5	14.00	10.50	8.40	7.00	600	5	16.00	12.00	9.60	8.00
650	5	15.17	11.38	9.10	7.58	650	5	17.33	13.00	10.40	8.67
700	5	16.33	12.25	9.80	8.17	700	5	18.67	14.00	11.20	9.33
750	5	17.50	13.13	10.50	8.75	750	5	20.00	15.00	12.00	10.00
800	5	18.67	14.00	11.20	9.33	800	5	21.33	16.00	12.80	10.67
850	5	19.83	14.88	11.90	9.92	850	5	22.67	17.00	13.60	11.33
900	5	21.00	15.75	12.60	10.50	900	5	24.00	18.00	14.40	12.00
950	5	22.17	16.63	13.30	11.08	950	5	25.33	19.00	15.20	12.67
1000	5	23.33	17.50	14.00	11.67	1000	5	26.67	20.00	16.00	13.33

## Dry Storage Chart # 6 - Formula #2

calculated storage area per .045 cu. ft. per meal served						calculated storage area per .05 cu. ft. per meal served					
meals served	useful storeroom height	0.3 usable storeroom floor area	0.4 usable storeroom floor area	0.5 usable storeroom floor area	0.6 usable storeroom floor area	meals served	useful storeroom height	0.3 usable storeroom floor area	0.4 usable storeroom floor area	0.5 usable storeroom floor area	0.6 usable storeroom floor area
200	5	6.00	4.50	3.60	3.00	200	5	6.67	5.00	4.00	3.33
250	5	7.50	5.63	4.50	3.75	250	5	8.33	6.25	5.00	4.17
300	5	9.00	6.75	5.40	4.50	300	5	10.00	7.50	6.00	5.00
350	5	10.50	7.88	6.30	5.25	350	5	11.67	8.75	7.00	5.83
400	5	12.00	9.00	7.20	6.00	400	5	13.33	10.00	8.00	6.67
450	5	13.50	10.13	8.10	6.75	450	5	15.00	11.25	9.00	7.50
500	5	15.00	11.25	9.00	7.50	500	5	16.67	12.50	10.00	8.33
550	5	16.50	12.38	9.90	8.25	550	5	18.33	13.75	11.00	9.17
600	5	18.00	13.50	10.80	9.00	600	5	20.00	15.00	12.00	10.00
650	5	19.50	14.63	11.70	9.75	650	5	21.67	16.25	13.00	10.83
700	5	21.00	15.75	12.60	10.50	700	5	23.33	17.50	14.00	11.67
750	5	22.50	16.88	13.50	11.25	750	5	25.00	18.75	15.00	12.50
800	5	24.00	18.00	14.40	12.00	800	5	26.67	20.00	16.00	13.33
850	5	25.50	19.13	15.30	12.75	850	5	28.33	21.25	17.00	14.17
900	5	27.00	20.25	16.20	13.50	900	5	30.00	22.50	18.00	15.00
950	5	28.50	21.38	17.10	14.25	950	5	31.67	23.75	19.00	15.83
1000	5	30.00	22.50	18.00	15.00	1000	5	33.33	25.00	20.00	16.67

## Dry Storage Chart # 7 - Formula #2

calculated storage area per .025 cu. ft. per meal served						calculated storage area per .03 cu. ft. per meal served					
meals served	useful storeroom height	0.3 usable storeroom floor area	0.4 usable storeroom floor area	0.5 usable storeroom floor area	0.6 usable storeroom floor area	meals served	useful storeroom height	0.3 usable storeroom floor area	0.4 usable storeroom floor area	0.5 usable storeroom floor area	0.6 usable storeroom floor area
200	6	2.78	2.08	1.67	1.39	200	6	3.33	2.50	2.00	1.67
250	6	3.47	2.60	2.08	1.74	250	6	4.17	3.13	2.50	2.08
300	6	4.17	3.13	2.50	2.08	300	6	5.00	3.75	3.00	2.50
350	6	4.86	3.65	2.92	2.43	350	6	5.83	4.38	3.50	2.92
400	6	5.56	4.17	3.33	2.78	400	6	6.67	5.00	4.00	3.33
450	6	6.25	4.69	3.75	3.13	450	6	7.50	5.63	4.50	3.75
500	6	6.94	5.21	4.17	3.47	500	6	8.33	6.25	5.00	4.17
550	6	7.64	5.73	4.58	3.82	550	6	9.17	6.88	5.50	4.58
600	6	8.33	6.25	5.00	4.17	600	6	10.00	7.50	6.00	5.00
650	6	9.03	6.77	5.42	4.51	650	6	10.83	8.13	6.50	5.42
700	6	9.72	7.29	5.83	4.86	700	6	11.67	8.75	7.00	5.83
750	6	10.42	7.81	6.25	5.21	750	6	12.50	9.38	7.50	6.25
800	6	11.11	8.33	6.67	5.56	800	6	13.33	10.00	8.00	6.67
850	6	11.81	8.85	7.08	5.90	850	6	14.17	10.63	8.50	7.08
900	6	12.50	9.38	7.50	6.25	900	6	15.00	11.25	9.00	7.50
950	6	13.19	9.90	7.92	6.60	950	6	15.83	11.88	9.50	7.92
1000	6	13.89	10.42	8.33	6.94	1000	6	16.67	12.50	10.00	8.33

### Dry Storage Chart # 8 - Formula #2

calculated storage area per .035 cu. ft. per meal served						calculated storage area per .04 cu. ft. per meal served					
meals served	useful storeroom height	0.3 usable storeroom floor area	0.4 usable storeroom floor area	0.5 usable storeroom floor area	0.6 usable storeroom floor area	meals served	useful storeroom height	0.3 usable storeroom floor area	0.4 usable storeroom floor area	0.5 usable storeroom floor area	0.6 usable storeroom floor area
200	6	3.89	2.92	2.33	1.94	200	6	4.44	3.33	2.67	2.22
250	6	4.86	3.65	2.92	2.43	250	6	5.56	4.17	3.33	2.78
300	6	5.83	4.38	3.50	2.92	300	6	6.67	5.00	4.00	3.33
350	6	6.81	5.10	4.08	3.40	350	6	7.78	5.83	4.67	3.89
400	6	7.78	5.83	4.67	3.89	400	6	8.89	6.67	5.33	4.44
450	6	8.75	6.56	5.25	4.38	450	6	10.00	7.50	6.00	5.00
500	6	9.72	7.29	5.83	4.86	500	6	11.11	8.33	6.67	5.56
550	6	10.69	8.02	6.42	5.35	550	6	12.22	9.17	7.33	6.11
600	6	11.67	8.75	7.00	5.83	600	6	13.33	10.00	8.00	6.67
650	6	12.64	9.48	7.58	6.32	650	6	14.44	10.83	8.67	7.22
700	6	13.61	10.21	8.17	6.81	700	6	15.56	11.67	9.33	7.78
750	6	14.58	10.94	8.75	7.29	750	6	16.67	12.50	10.00	8.33
800	6	15.56	11.67	9.33	7.78	800	6	17.78	13.33	10.67	8.89
850	6	16.53	12.40	9.92	8.26	850	6	18.89	14.17	11.33	9.44
900	6	17.50	13.13	10.50	8.75	900	6	20.00	15.00	12.00	10.00
950	6	18.47	13.85	11.08	9.24	950	6	21.11	15.83	12.67	10.56
1000	6	19.44	14.58	11.67	9.72	1000	6	22.22	16.67	13.33	11.11

## Dry Storage Chart # 9 - Formula #2

calculated storage area per .045 cu. ft. per meal served						calculated storage area per .05 cu. ft. per meal served					
meals served	useful storeroom height	0.3 usable storeroom floor area	0.4 usable storeroom floor area	0.5 usable storeroom floor area	0.6 usable storeroom floor area	meals served	useful storeroom height	0.3 usable storeroom floor area	0.4 usable storeroom floor area	0.5 usable storeroom floor area	0.6 usable storeroom floor area
200	6	5.00	3.75	3.00	2.50	200	6	5.56	4.17	3.33	2.78
250	6	6.25	4.69	3.75	3.13	250	6	6.94	5.21	4.17	3.47
300	6	7.50	5.63	4.50	3.75	300	6	8.33	6.25	5.00	4.17
350	6	8.75	6.56	5.25	4.38	350	6	9.72	7.29	5.83	4.86
400	6	10.00	7.50	6.00	5.00	400	6	11.11	8.33	6.67	5.56
450	6	11.25	8.44	6.75	5.63	450	6	12.50	9.38	7.50	6.25
500	6	12.50	9.38	7.50	6.25	500	6	13.89	10.42	8.33	6.94
550	6	13.75	10.31	8.25	6.88	550	6	15.28	11.46	9.17	7.64
600	6	15.00	11.25	9.00	7.50	600	6	16.67	12.50	10.00	8.33
650	6	16.25	12.19	9.75	8.13	650	6	18.06	13.54	10.83	9.03
700	6	17.50	13.13	10.50	8.75	700	6	19.44	14.58	11.67	9.72
750	6	18.75	14.06	11.25	9.38	750	6	20.83	15.63	12.50	10.42
800	6	20.00	15.00	12.00	10.00	800	6	22.22	16.67	13.33	11.11
850	6	21.25	15.94	12.75	10.63	850	6	23.61	17.71	14.17	11.81
900	6	22.50	16.88	13.50	11.25	900	6	25.00	18.75	15.00	12.50
950	6	23.75	17.81	14.25	11.88	950	6	26.39	19.79	15.83	13.19
1000	6	25.00	18.75	15.00	12.50	1000	6	27.78	20.83	16.67	13.89

## Dry Storage Chart # 10 - Formula #2

calculated storage area per .025 cu. ft. per meal served						calculated storage area per .03 cu. ft. per meal served					
meals served	useful storeroom height	0.3 usable storeroom floor area	0.4 usable storeroom floor area	0.5 usable storeroom floor area	0.6 usable storeroom floor area	meals served	useful storeroom height	0.3 usable storeroom floor area	0.4 usable storeroom floor area	0.5 usable storeroom floor area	0.6 usable storeroom floor area
200	7	2.38	1.79	1.43	1.19	200	7	2.86	2.14	1.71	1.43
250	7	2.98	2.23	1.79	1.49	250	7	3.57	2.68	2.14	1.79
300	7	3.57	2.68	2.14	1.79	300	7	4.29	3.21	2.57	2.14
350	7	4.17	3.13	2.50	2.08	350	7	5.00	3.75	3.00	2.50
400	7	4.76	3.57	2.86	2.38	400	7	5.71	4.29	3.43	2.86
450	7	5.36	4.02	3.21	2.68	450	7	6.43	4.82	3.86	3.21
500	7	5.95	4.46	3.57	2.98	500	7	7.14	5.36	4.29	3.57
550	7	6.55	4.91	3.93	3.27	550	7	7.86	5.89	4.71	3.93
600	7	7.14	5.36	4.29	3.57	600	7	8.57	6.43	5.14	4.29
650	7	7.74	5.80	4.64	3.87	650	7	9.29	6.96	5.57	4.64
700	7	8.33	6.25	5.00	4.17	700	7	10.00	7.50	6.00	5.00
750	7	8.93	6.70	5.36	4.46	750	7	10.71	8.04	6.43	5.36
800	7	9.52	7.14	5.71	4.76	800	7	11.43	8.57	6.86	5.71
850	7	10.12	7.59	6.07	5.06	850	7	12.14	9.11	7.29	6.07
900	7	10.71	8.04	6.43	5.36	900	7	12.86	9.64	7.71	6.43
950	7	11.31	8.48	6.79	5.65	950	7	13.57	10.18	8.14	6.79
1000	7	11.90	8.93	7.14	5.95	1000	7	14.29	10.71	8.57	7.14

## Dry Storage Chart # 11 - Formula #2

calculated storage area per .035 cu. ft. per meal served						calculated storage area per .04 cu. ft. per meal served					
meals served	useful storeroom height	0.3 usable storeroom floor area	0.4 usable storeroom floor area	0.5 usable storeroom floor area	0.6 usable storeroom floor area	meals served	useful storeroom height	0.3 usable storeroom floor area	0.4 usable storeroom floor area	0.5 usable storeroom floor area	0.6 usable storeroom floor area
200	7	3.33	2.50	2.00	1.67	200	7	3.81	2.86	2.29	1.90
250	7	4.17	3.13	2.50	2.08	250	7	4.76	3.57	2.86	2.38
300	7	5.00	3.75	3.00	2.50	300	7	5.71	4.29	3.43	2.86
350	7	5.83	4.38	3.50	2.92	350	7	6.67	5.00	4.00	3.33
400	7	6.67	5.00	4.00	3.33	400	7	7.62	5.71	4.57	3.81
450	7	7.50	5.63	4.50	3.75	450	7	8.57	6.43	5.14	4.29
500	7	8.33	6.25	5.00	4.17	500	7	9.52	7.14	5.71	4.76
550	7	9.17	6.88	5.50	4.58	550	7	10.48	7.86	6.29	5.24
600	7	10.00	7.50	6.00	5.00	600	7	11.43	8.57	6.86	5.71
650	7	10.83	8.13	6.50	5.42	650	7	12.38	9.29	7.43	6.19
700	7	11.67	8.75	7.00	5.83	700	7	13.33	10.00	8.00	6.67
750	7	12.50	9.38	7.50	6.25	750	7	14.29	10.71	8.57	7.14
800	7	13.33	10.00	8.00	6.67	800	7	15.24	11.43	9.14	7.62
850	7	14.17	10.63	8.50	7.08	850	7	16.19	12.14	9.71	8.10
900	7	15.00	11.25	9.00	7.50	900	7	17.14	12.86	10.29	8.57
950	7	15.83	11.88	9.50	7.92	950	7	18.10	13.57	10.86	9.05
1000	7	16.67	12.50	10.00	8.33	1000	7	19.05	14.29	11.43	9.52

### Dry Storage Chart # 12 - Formula #2

calculated storage area per .045 cu. ft. per meal served						calculated storage area per .05 cu. ft. per meal served					
meals served	useful storeroom height	0.3 usable storeroom floor area	0.4 usable storeroom floor area	0.5 usable storeroom floor area	0.6 usable storeroom floor area	meals served	useful storeroom height	0.3 usable storeroom floor area	0.4 usable storeroom floor area	0.5 usable storeroom floor area	0.6 usable storeroom floor area
200	7	4.29	3.21	2.57	2.14	200	7	4.76	3.57	2.86	2.38
250	7	5.36	4.02	3.21	2.68	250	7	5.95	4.46	3.57	2.98
300	7	6.43	4.82	3.86	3.21	300	7	7.14	5.36	4.29	3.57
350	7	7.50	5.63	4.50	3.75	350	7	8.33	6.25	5.00	4.17
400	7	8.57	6.43	5.14	4.29	400	7	9.52	7.14	5.71	4.76
450	7	9.64	7.23	5.79	4.82	450	7	10.71	8.04	6.43	5.36
500	7	10.71	8.04	6.43	5.36	500	7	11.90	8.93	7.14	5.95
550	7	11.79	8.84	7.07	5.89	550	7	13.10	9.82	7.86	6.55
600	7	12.86	9.64	7.71	6.43	600	7	14.29	10.71	8.57	7.14
650	7	13.93	10.45	8.36	6.96	650	7	15.48	11.61	9.29	7.74
700	7	15.00	11.25	9.00	7.50	700	7	16.67	12.50	10.00	8.33
750	7	16.07	12.05	9.64	8.04	750	7	17.86	13.39	10.71	8.93
800	7	17.14	12.86	10.29	8.57	800	7	19.05	14.29	11.43	9.52
850	7	18.21	13.66	10.93	9.11	850	7	20.24	15.18	12.14	10.12
900	7	19.29	14.46	11.57	9.64	900	7	21.43	16.07	12.86	10.71
950	7	20.36	15.27	12.21	10.18	950	7	22.62	16.96	13.57	11.31
1000	7	21.43	16.07	12.86	10.71	1000	7	23.81	17.86	14.29	11.90

## **PART 8 - WAREWASHING FACILITIES**

### **MANUAL WAREWASHING**

For manual washing and sanitizing of utensils, provide a stainless steel sink with no fewer than 3 compartments. The sink compartments shall be large enough to hold the largest pot, pan or piece of equipment. Each compartment shall be supplied with adequate hot and cold potable running water. Integral drainboards of adequate size shall be provided on both sides of the sink for cleaned and soiled utensils. When approved, 2 compartment sinks may be allowable under certain conditions. See figure #8-1.

Pitch the drainboards and dish tables a minimum of 1/8" per foot and direct the drainage into the sink. Drainboards should generally be at least the same size as that of the sink compartments. Recommended size is 36-48" long and 30" wide.

Locate a floor drain in the immediate vicinity of the sink in areas where wet pots, utensils and equipment are air-drying. Approved racks, shelves or dish tables are to be provided adjacent to the warewash sink.

Provide adequate facilities for preflushing or prescrapping equipment and utensils.

An approved chemical test kit for determining sanitizer strength shall be available and used.

Working supplies of cleaners and sanitizers must be stored in an approved location. A recommended storage location is on a wire shelf below the drainboard of the 3 compartment sink.

### **MECHANICAL WAREWASHING**

The waste line for all mechanical warewashing machines must not be directly connected to the sewer line. Except that the waste line may be connected directly on the inlet side of a properly vented floor drain when the floor drain is within 5' of the warewashing machine and the drain line from the machine is properly trapped and vented. See figure #8-2.

Adequate facilities shall be provided to air dry washed utensils and equipment. Storage facilities shall be provided to store cleaned and sanitized utensils and equipment at least 12" above the floor on fixed shelves or in enclosed cabinets protected from splash, dust, overhead plumbing or other contamination.

## DETERMINING WAREWASH MACHINE CAPACITY

The capacity of the dishwashing machines should be based on the peak number and type of dishes, utensils, flatware, etc. that must be washed per hour. One way to find the capacity in racks per hour for each make and model of machine is to refer to the manufacturer's specification sheets. To determine the required capacity refer to the following guide:

Each 20" x 20" dishrack will accommodate:

- 16 - 9" dinner plates
- 25 - water glasses
- 16 - coffee cups
- 100 - pieces of flatware

Only 70% of the listed capacity (in racks per hour) should be considered as an average capacity. Consult the manufacturers' specification sheets ("cut sheets") for optimum capacity.

A suggested formula to determine the number of dishracks required per hour for a restaurant serving 200 meals at lunch is as follows:

200 plates	= $\frac{200 \text{ plates}}{16 \text{ plates/rack}} = 13 \text{ racks}$
200 water glasses	= $\frac{200 \text{ glasses}}{25 \text{ glasses/rack}} = 8 \text{ racks}$
200 coffee cups	= $\frac{200 \text{ coffee cups}}{16 \text{ cups/rack}} = 13 \text{ racks}$
200 pieces of flatware	= $\frac{200 \text{ pieces}}{100 \text{ pieces/rack}} = 2 \text{ racks}$

Required total working capacity = 36 racks/hour

Since this figure is 70% of the listed capacity, a mechanical dishwasher with a minimum listed capacity of:

$$\frac{36}{.70 (70\%)} = 51 \text{ racks/hour would be recommended}$$

An adequate facility for preflushing or prescrapping shall be provided on the soiled dish side of the dishwashing machine.

Drainboards shall be provided, be of adequate size for the proper handling of utensils, and located so as not to interfere with the proper use of the warewashing facilities. Mobile dish tables may be acceptable for use in lieu of drainboards.

## CHEMICAL WAREWASHING

Chemical warewashing machines shall meet nationally recognized standards and be certified or classified by an ANSI accredited certification program. The installation must conform to applicable code requirements. Among the specific requirements for the installation of an approved chemical warewashing machine are the following:

1. The chemical sanitizing feeder must meet nationally recognized standards and be certified or classified by an ANSI accredited certification program and be compatible with the specific make and model of machine in question.
2. An approved chemical test kit for determining sanitizer strength shall be available and used.
3. A visual flow indicator must be provided to monitor the operation of the sanitizing agent feeder. Other indication devices such as audible alarms may also be used. The flow indication devices must be installed so as to be conspicuous to the operator.

Adequate facilities shall be provided to air dry washed utensils and equipment. Storage facilities shall be provided to store cleaned and sanitized utensils and equipment at least 12" above the floor, protected from splash, dust, overhead plumbing or other contamination; on fixed shelves; or in enclosed cabinets. The plan must specify location and facilities used for storing all utensils and equipment.

## WAREWASHING UTILIZING HOT WATER SANITIZATION

A commercial warewashing machine for mechanical warewashing utilizing hot water for sanitization shall be provided that is in compliance with the standards of an ANSI accredited certification program. The installation and required accessories shall be in conformance with local applicable plumbing codes.

An approved maximum registering thermometer or high temperature test papers shall be available and used.

If the detergent dispenser or drying agent dispenser is not equipped with an integral backflow prevention device, the installation point of the dispenser shall be below the vacuum breaker on the warewashing machine. See figure #8-3.

---

Other references are available for additional formulas and information. One such reference includes: Salvato Textbook. Environmental Engineering & Sanitation 4<sup>th</sup> Edition. Copyright John Wiley & Sons, Inc. United States. 1992.

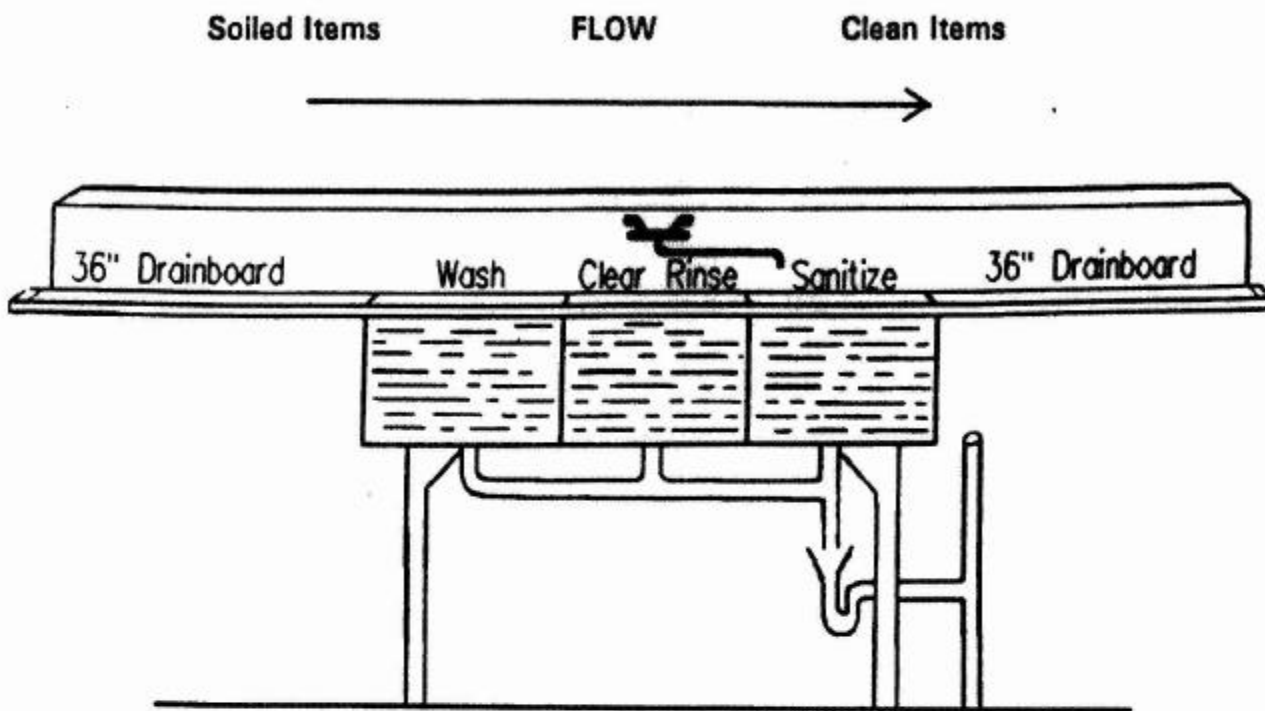

Recommended warewashing arrangement using three-compartment sink. Drainboards for soiled dishes and for cleaned utensils must be adequate. A 36" drainboard should have a pitch of  $\frac{1}{8}$ " to  $\frac{3}{8}$ " per foot toward the sink.

### Three Compartment Sink With Indirect Waste

Figure 8-1

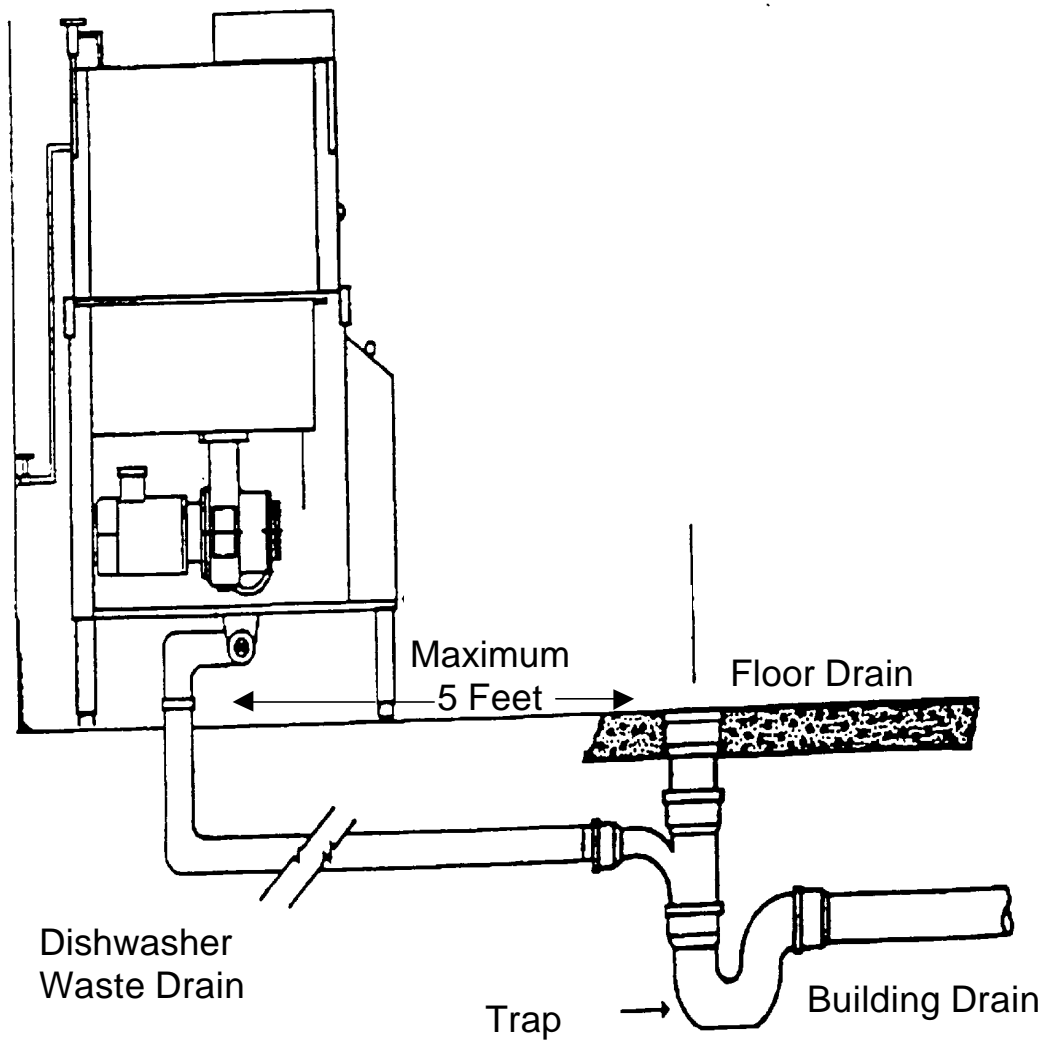

## Warewashing Machine With a Direct Waste Connection

Figure 8-2

**Point of installation for detergent dispenser and drying agent dispenser**

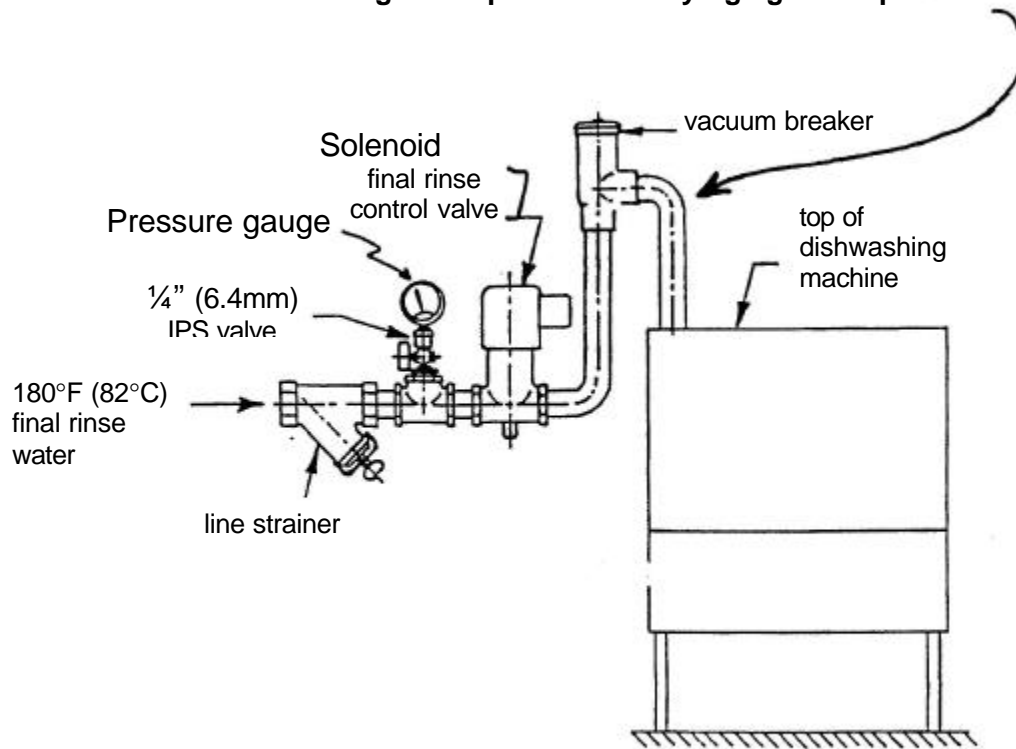

# **Recommended Warewashing Machine Installation**

**Figure 8-3**

## PART 9 - DETERMINING HOT WATER SUPPLY REQUIREMENTS

The hot water supply shall be sufficient to satisfy the continuous and peak hot water demands of the establishment. Hot water for handwashing shall be of a temperature of at least 110°F. Hot water for mechanical dishwashing must be 150°F-165°F for washing and 165°F-180°F for sanitizing. The temperature of the wash solution in spray-type warewashers that use chemicals to sanitize may not be less than 120°F. The water temperature for manual hot water sanitization must be at least 171°F. For purposes of sizing the hot water generating capability, assume a supply temperature requirement of 140°F to each fixture and to the mechanical dishwashing machines.

In the absence of specific hot water usage figures for equipment, the following chart may be used to provide an approximation:

<u>Equipment Type</u>	<u>Gallons Per Hour</u>	
	<u>High</u>	<u>Low</u>
Vegetable sink	15	15
Single pot sink	20	15
Double pot sink	40	30
Triple pot sink	60	45
Pre-rinse for dishes-shower head type	45	45
Bar sink-three compartment	20	
Bar sink-four compartment	25	
Chemical sanitizing glasswasher	60	
Lavatory	5	5
Cook sink	10	10
Hot water filling faucet	15	15
Bain Marie	10	10
Coffee urn	5	5
Kettle stand	5	5
Garbage can washer	50	50
Nine and twelve pound clothes washer	45	45
Sixteen pound clothes washer	60	60
Employee shower	20	20

High - To be used when multi-use eating utensils are utilized

Low - To be used in carry-out food operations where single service eating utensils are utilized.

One way to estimate the projected hot water demand (gallons per hour final rinse) of mechanical warewashing machines, pot and pan washers and silverware washers, is to refer to the manufacturers' specification sheet for the particular make and model of the machine.

In order to determine the required capacity and recuperative rate of the hot water generating equipment it will be necessary to calculate both the demand in gallons per hour (gph) and temperature rise required (assume an incoming water temperature of 40°F to the food establishment unless specific data are available) for each piece of equipment. These figures can then be converted to BTU's (for gas fired heaters) or KW (for electrical heaters). The required BTU or KW capacity of the heater will then be determined by adding up the individual BTU or KW requirements for each piece of equipment.

Note: To calculate BTU's or KW's, use the following formulas: (1 gallon of water = 8.33lbs)

For gas heaters (in BTU's):  
 Required BTU = 
$$\frac{\text{Gallons per hour of water} \times \text{Temp. rise} \times 8.33}{.70 \text{ (operating efficiency)}}$$

For electrical heaters (in KW):  
 Required KW = 
$$\frac{\text{Gallons per hour of water} \times \text{Temp. rise} \times 8.33}{3412 \text{ (BTU's per KW)}}$$

The following example will illustrate of the above method of approximating the size of the hot water heater needed for specified equipment:

<u>Equipment</u>	<u>Gallons Per Hour Demand from Chart</u>	<u>Temperature Required</u>	<u>Temp. Rise</u>
3 Comp't sink	60	140°F	100°F
	$\frac{60 \text{ (gph)} \times 100 \text{ degree temp. rise} \times 8.33}{.70 \text{ (operating efficiency)}}$		= 71,400 BTU's

OR

$$\frac{60 \text{ (gph)} \times 100 \text{ degree temp rise} \times 8.33}{3412 \text{ (BTU's per KW)}}$$
 = 14.65 KW

Assume an incoming water temperature of 40°F into the food establishment.

<u>Equipment</u>	<u>Gallons Per Hour Demand from Chart</u>	<u>Temperature Required</u>	<u>Temp. Rise</u>
Hand sink	5	110°F	70°F

$$\frac{5 \text{ (gph)} \times 70 \text{ degree temp rise} \times 8.33}{.70 \text{ (operating efficiency)}} = 4,165 \text{ BTU's}$$

OR

$$\frac{5 \text{ (gph)} \times 70 \text{ degree temp rise} \times 8.33}{3412 \text{ (BTU per KW)}} = 0.85 \text{ KW}$$

This example assumes an incoming water temperature of 40°F into the food establishment.

<u>Equipment</u>	<u>Gallons Per Hour Demand from Chart</u>	<u>Temperature Required</u>	<u>Temp Rise</u>
Chemical/ Mechanical warewasher	64	140°F	100°F

$$\frac{64 \text{ (gph)} \times 100 \text{ degree temp rise} \times 8.33}{.70 \text{ (operating efficiency)}} = 76,160 \text{ BTU's}$$

OR

$$\frac{64 \text{ (gph)} \times 100 \text{ degree temp rise} \times 8.33}{3412 \text{ (BTU per KW)}} = 15.62 \text{ KW}$$

This example assumes an incoming water temperature of 40°F into the food establishment and a hot water heater delivery of 140°F hot water to the unit.

<u>Equipment</u>	<u>Gallons Per Hour Demand from Chart</u>	<u>Temperature Required</u>	<u>Temp Rise</u>
Hot water Sanitizing Mechanical warewasher	64	180°F	40°F

$$\frac{64 \text{ (gph)} \times 40 \text{ degree temp rise} \times 8.33}{.70 \text{ (operating efficiency)}} = 30,464 \text{ BTU's}$$

$$\frac{64 \text{ (gph)} \times 40 \text{ degree temp rise} \times 8.33}{3412 \text{ (BTU per KW)}} = 6.2 \text{ KW}$$

For mechanical warewashing, assume a hot water demand based on a primary rise in temperature to 140°F. A booster heater must then be provided to boost the required gph demand an additional 40°F to attain the required 180°F final rinse temperature.

For the above example, the total demand in BTU's or KW for the primary hot water heater would be:

3 Compartment sink	=	71,400 BTU or 14.65 KW
1 Hand sink	=	4,165 BTU or 0.85 KW
<u>1 Mechanical warewasher</u>	<u>=</u>	<u>76,160 BTU or 15.62 KW</u>
<b>TOTAL DEMAND</b>	<b>=</b>	<b>151,725 BTU or 31.12 KW</b>

A booster heater for the warewasher must be provided and sized to supply an additional 30,464 BTU or 6.2 KW.

All hot water generating equipment should conform to nationally recognized standards and be certified or classified by an ANSI certification program. The manufacturers' specification sheets (cut sheets) should be consulted for hot water supply requirements

The above provides one method of approximation. Other suitably developed calculations may be submitted for consideration. See the Guidelines from the California Directors of Environmental Health as an example of other suitable calculations, also attached are other example calculations from North Carolina's Department of Environmental Health, Food, Lodging, and Institutional Sanitation Branch.

# **GUIDELINES FOR SIZING WATER HEATERS**

California Conference of Directors of Environmental Health  
September, 1995

## **I. BACKGROUND**

A critical factor in preventing foodborne illnesses in a food facility is the provision of an adequate supply of hot water for the washing of hands, utensils, equipment, and the facility itself. The installation of a properly sized water heater will ensure that a sufficient amount of hot water will be available at all times.

## **II. PURPOSE**

The purpose of these guidelines is to provide a set of criteria that will assist architects, designers, contractors and owners in properly sizing water heaters to adequately meet the anticipated hot water demands of food facilities in California.

Food facilities with water heaters sized according to these criteria should be capable of complying with the requirements for providing an adequate hot water supply as required by the California Uniform Retail Food Facilities Law.

## **III. LEGAL AUTHORITY**

California Health and Safety Code, Chapter 4, Article 8, Sections 27623, 27624, 27625, 27627, and 27627.3.

## **IV. DEFINITIONS**

- **Booster Heater:** An instantaneous water heater designed and intended to raise the temperature of hot water to a higher temperature for a specific purpose, such as for the sanitizing rinse on a high temperature automatic dishmachine.
- **BTU (British Thermal Unit):** The quantity of heat required to raise the temperature of one pound of water one degree Fahrenheit.
- **GPH (Gallons Per Hour):** The amount of water, in gallons, that is used each hour by the plumbing fixtures and equipment, such as dishmachines.
- **GPM (Gallons Per Minute):** The amount of water, in gallons, flowing through a plumbing fixture or through an instantaneous water heater per minute.
- **Instantaneous Water Heater:** A water heater that generates hot water on demand.
- **KW (Kilowatt):** A unit of electric power equal to 1,000 watts.
- **Rise:** The temperature of water as it leaves the water heater minus the temperature of the water entering the water heater.
- **Storage Water Heater:** A water heater that incorporates a thermostat, a storage tank, and a burner or heating elements, to heat and maintain the water within the tank at a specific temperature.
- **Thermal Efficiency:** The measure of the overall efficiency of the water heater, taking into consideration loss of energy due to combustion, radiation, convection and conduction of heat from the unit.

**V. GENERAL REQUIREMENTS**

- A. A water heater shall be provided which is **capable** of generating an adequate supply of hot water, at a temperature of at least 120° Fahrenheit, to all sinks, janitorial facilities, and other equipment and fixtures that use hot water, at all times.
- B. Water heaters and their installation must be in compliance with all local building code requirements.
- C. Water heaters that use reclaimed heat from equipment to heat water must be evaluated on a case by case basis.

**VI. SIZING REQUIREMENTS FOR STORAGE WATER HEATERS**

- A. For food facilities that utilize multiservice eating and drinking utensils, the water heater shall have a recovery rate equal to or greater than 100% of the computed hourly hot water demand, in gallons per hour (GPH).
- B. For food facilities that use only single-service eating and drinking utensils, or don't use utensils at all, the water heater shall have a recovery rate equal to or greater than 80% of the computed hourly hot water demand, in GPH.
- C. For food facilities that handle and sell **only** prepackaged foods, a water heater with a minimum storage capacity of ten gallons must be provided.
- D. The hourly hot water demand for the food facility, in GPH, is calculated by adding together the estimated hot water demands for all sinks and other equipment, such as dishmachines, which utilize hot water. The estimated hot water demands for sinks and other equipment that utilize hot water are listed in Appendix I. The hot water demands for automatic warewashers, such as dishmachines, glasswashers, and potwashers are found in NSF International listings or listings established by other nationally recognized testing laboratories.
- E. The following examples are provided to explain how to calculate the total hourly hot water demand:

- 1. Food facility that utilizes only single service eating and drinking utensils:

Assume:

1 18" X 18" three compartment sink	42 GPH
2 hand lavatories	10 GPH (5 GPH each)
1 janitorial sink	<u>15 GPH</u>
	67 GPH total hourly hot water demand

67 GPH X 80% allowance for single service utensils = 54 GPH

For the food facility in this example, a water heater would be required which will recover 54 GPH.

- 2. Food facility that utilizes multiservice eating and drinking utensils:

Assume:

1 18" X 18" three compartment sink	42 GPH
automatic dishmachine	80 GPH
hand spray pre-rinse	45 GPH
one compartment food preparation sink	5 GPH

2 hand lavatories	10 GPH (5 GPH each)
1 janitorial sink	<u>15 GPH</u>
	197 GPH total hourly hot water demand

Since the food facility in this example uses multiservice eating and drinking utensils, 100% of the computed hourly hot water demand must be provided. Therefore, a water heater would be required which will recover 197 GPH.

- F. To compute a BTU or KW rating for the required hourly hot water demand found in example #1 the following formulas should be used:

Formula 1 (for gas water heaters)

$$\frac{\text{BTU input} = \text{GPH} \times \text{°Rise}^1 \times 8.33 \text{ lb./gallon of water}}{\text{Thermal Efficiency}^2}$$

$$\frac{\text{BTU input} = 54 \text{ GPH} \times 50\text{°F} \times 8.33 \text{ lb.}}{.75}$$

$$\text{BTU input} = 29,988$$

<sup>1</sup> The average temperature of tap water varies throughout the state depending upon the location, elevation, and time of year. In order to properly size the water heater check with your local health agency to determine the required rise. For the purposes of these guidelines a tap water temperature of 70° Fahrenheit will be used. Therefore, to achieve a temperature of 120° Fahrenheit at the faucet, the required rise would be 50°.

<sup>2</sup> The thermal efficiency for gas water heaters, unless otherwise listed by NSF International or other nationally recognized testing laboratories, will be assumed to be 75%.

Formula 2 (for electric water heaters)

$$\frac{\text{KW input} = \text{GPH} \times \text{°Rise} \times 8.33 \text{ lb./gallon of water}}{\text{Thermal Efficiency}^1 \times 3412 \text{ BTU/KW}}$$

$$\frac{\text{KW input} = 54 \text{ GPH} \times 50\text{°F} \times 8.33 \text{ lb.}}{.98 \times 3412 \text{ BTU/KW}}$$

$$\text{KW input} = 6.7$$

<sup>1</sup> The thermal efficiency for electric water heaters, unless otherwise listed by NSF International or other nationally recognized testing laboratories, will be assumed to be 98%. Sizing tables for gas and electric water heaters are found in Appendices II and III respectively.

**VII. SIZING REQUIREMENTS FOR INSTANTANEOUS WATER HEATERS**

- A. One of the advantages of an instantaneous water heater is its ability to provide a continuous supply of hot water. However, since the water passes through a heat exchanger, the water must flow through the unit slowly to assure proper heat transfer. Therefore, the quantity, or rate, at which the hot water is delivered can be significantly less than that provided by a storage water heater. When hot water is utilized at several locations of the food facility at the same time the flow of hot water to each fixture can be severely restricted. As a result of the restricted output of instantaneous water heaters, more than one unit may be required, depending on the numbers and types of sinks and equipment present. Due to the limitations inherent in the design of instantaneous water heaters, some local health agencies may restrict or prohibit their usage. Check with your local health agency prior to installing an instantaneous water heater in order to

determine their requirements.

- B. Instantaneous water heaters must be sized to provide hot water of at least 120° Fahrenheit, and at a rate of at least two gallons per minute (GPM), to each sink and fixture that utilizes hot water. (Note: Hand lavatories must receive at least 1/2 GPM.) The following example is provided to explain how this sizing criteria is applied:

Assume:

1 18" X 18" three compartment sink	2 GPM
2 hand lavatories	1 GPM (1/2 GPM each)
1 janitorial sink	<u>2 GPM</u>
	5 GPM

- C. In the example given above, one or more instantaneous water heaters would have to be provided in order to supply a total of at least 5 GPM.
- D. Food facilities that install an automatic warewashing machine that utilizes a large quantity of hot water may be required to provide an instantaneous water heater exclusively for the warewashing machine. NSF International listings or listings established by other nationally recognized testing laboratories are used to determine the minimum GPM hot water demand for automatic warewashing machines.

#### **VIII. REQUIREMENTS FOR BOOSTER HEATERS**

- A. When a hot water sanitizing warewashing machine is used, a booster heater must be provided that will raise the incoming general purpose hot water up to at least 180° Fahrenheit for the final sanitizing rinse cycle.
- B. When sizing a booster heater, the hot water demand for the warewashing final sanitizing rinse cycle should be obtained from the NSF International listings or listings established by other nationally recognized testing laboratories.
- C. The formulas for calculating BTU or KW input listed in section VI.F. should be used when determining the minimum required size for a booster heater.
- D. When a booster heater is installed below a drainboard, it shall be installed at least six inches above the floor and away from the wall, and in a manner that will allow accessibility for proper cleaning and servicing.

#### **IX. RECIRCULATION PUMPS**

- A. Where fixtures are located more than sixty feet from the water heater, a recirculation pump must be installed, in order to ensure that water reaches the fixture at a temperature of at least 120° Fahrenheit.
- B. In some cases it may be more practical to install a separate, smaller water heater for remote fixtures, such as for restroom handsinks.

#### **X. INSTALLATION REQUIREMENTS**

- A. Where feasible, water heaters should be located in an area of the food facility separated from all food and utensil handling areas.
- B. The Uniform Building Code prohibits the installation of gas water heaters in restrooms or change rooms.

- C. Water heaters shall be mounted in one of the following manners:
1. On six inch high, easily cleanable legs.
  2. On a four inch high coved curb base. All openings between the water heater and the base must be sealed in a watertight manner.
  3. On a properly finished and installed wall pedestal, positioned so that it is out of the work and traffic space.
  4. In an easily accessible location above a suspended ceiling. Where a permanently installed ladder is required to access the water heater, the ladder shall not be installed above a food or utensil handling area.
- Note: The local health agency may allow alternate installation methods when a water heater is installed in an area separated from food and utensil handling areas, such as in a mechanical room.
- D. A common mistake with electric water heaters is the ordering and installing of a water heater with an upper element of 4500 watts, a bottom element of 4500 watts, and a total connected (or maximum) wattage of 4500 watts. On such a water heater only one element is operating at any one time. Many individuals do not observe the total connected wattage and assume that because each of the elements is 4500 watts their water heater has an input rating of 9000 watts. Water heater manufacturers have specific procedures for rewiring an electric water heater so that the upper and lower elements are operating simultaneously. Some manufacturers only permit rewiring in the factory. Field modifications will normally void warranties and any listings that the unit comes with. Prior to acceptance of a field modified water heater, the local health agency should ensure that the modifications were performed according to the manufacturer's recommendations and with the approval of the local building officials. The data plate on a field modified water heater must be changed to reflect the total connected wattage rating with both elements operating simultaneously.
- E. When multiple water heaters are connected, they must be installed in parallel, not in series (See Appendix IV).

APPENDIX I

**HOURLY HOT WATER DEMAND TABLE**

**Utensil Sinks**

18" X 18" .....14 gallons per compartment

24" X 24" .....25 gallons per compartment

Custom sink sizes can be calculated using the following formula:

$$\text{Length X Width X Average Depth X 7.5 = gallons per compartment}$$

**Bar Sinks**

6 gallons per compartment

**Food Preparation Sinks**

5 gallons per sink

**Janitorial Sinks**

15 gallons per sink

**Garbage Can Wash Facility**

15 gallons per facility

**Hand Sinks**

5 gallons per sink

**Pre-rinse Units**

Hand spray type.....45 gallons

Other types.....Refer to manufacturer's specifications for the equipment

**Clothes Washers**

9 and 12 pound washers.....45 gallons

16 pound washers.....60 gallons

**Employee Shower**

20 gallons per shower

**Other Fixtures That Utilize Hot Water**

Refer to manufacturer's specifications for the equipment

**APPENDIX II**

**SIZING TABLE FOR GAS WATER HEATERS**

Gallons Per Hour Delivery At Indicated Temperature Rise

BTU (X 1000)	40°F	50°F	60°F	70°F
5	11	9	8	6
10	23	18	15	13
15	34	27	23	19
20	45	36	30	26
25	56	45	38	32
30	68	54	45	39
35	79	63	53	45
40	90	72	60	51
45	101	81	68	58
50	113	90	75	64
55	124	99	83	71
60	135	108	90	77
65	146	117	98	84
70	158	126	105	90
75	169	135	113	96
80	180	144	120	103
85	191	153	128	109
90	203	162	135	116
95	214	171	143	122
100	225	180	150	129
105	236	189	158	135
110	248	198	165	141
115	259	207	173	148
120	270	216	180	154
125	281	225	188	161
130	293	234	195	167
135	304	243	203	174
140	315	252	210	180
145	326	261	218	187
150	338	270	225	193
155	349	279	233	199
160	360	288	240	206
165	371	297	248	212
170	383	306	255	219
175	394	315	263	225
180	405	324	270	232
185	416	333	278	238
190	428	342	285	244
195	439	351	293	251
200	450	360	300	257
205	461	369	308	264
210	473	378	315	270
215	484	387	323	277
220	495	396	330	283
225	506	405	338	289
230	518	414	345	296
235	529	423	353	302
240	540	432	360	309
245	551	441	368	315
250	563	450	375	322

APPENDIX III

**SIZING TABLE FOR ELECTRIC WATER HEATERS**

Gallons Per Hour Delivery At Indicated Temperature Rise

KW	40°F	50°F	60°F	70°F
1	10	8	7	6
2	20	16	13	11
3	30	24	20	17
4	40	32	27	23
5	50	40	33	29
6	60	48	40	34
7	70	56	47	40
8	80	64	54	46
9	90	72	60	52
10	100	80	67	57
11	110	88	74	63
12	120	96	80	69
13	130	104	87	75
14	141	112	94	80
15	151	120	100	86
16	161	128	107	92
17	171	136	114	97
18	181	145	120	103
19	191	153	127	109
20	201	161	134	115
21	211	169	141	120
22	221	177	147	126
23	231	185	154	132
24	241	193	161	138
25	251	201	167	143
26	261	209	174	149
27	271	217	181	155
28	281	225	187	161
29	291	233	194	166
30	301	241	201	172
31	311	249	207	178
32	321	257	214	184
33	331	265	221	189
34	341	273	227	195
35	351	281	234	201
36	361	289	241	206
37	371	297	248	212
38	381	305	254	218
39	391	313	261	224
40	401	321	268	229
41	411	329	274	235
42	422	337	281	241
43	432	345	288	247
44	442	353	294	252
45	452	361	301	258
46	462	369	308	264
47	472	377	314	270
48	482	385	321	275
49	492	393	328	281
50	502	401	335	287

APPENDIX IV

Water Heaters Installed In Parallel

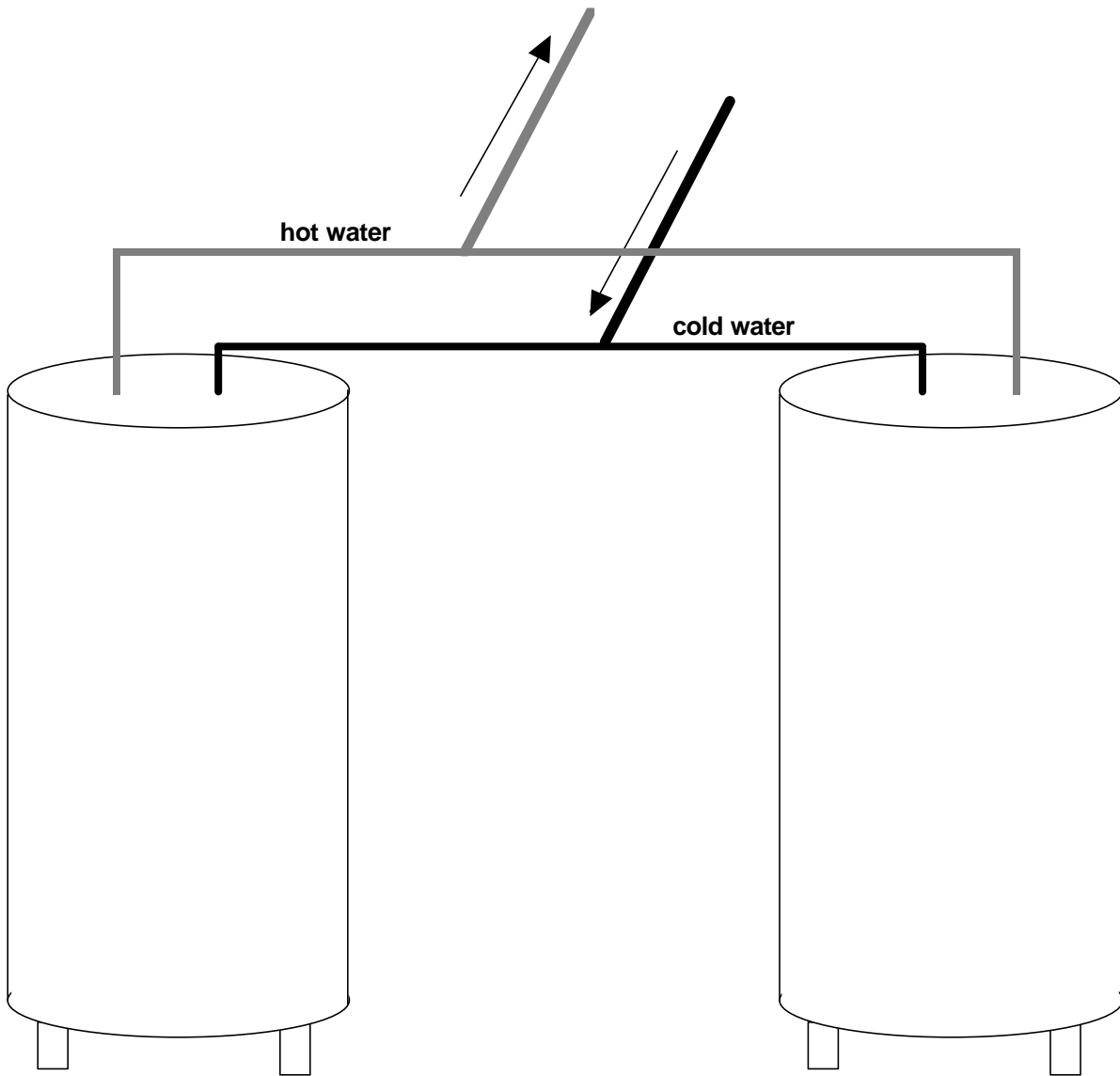

## **WATER HEATER WORKSHEET AND SAMPLE CALCULATIONS**

Cited below, and on the next few pages, is information, and sample calculations from the North Carolina Department of Health, Food, Lodging, and Institutional Sanitation Branch.

### **DETERMINING HOT WATER SUPPLY REQUIREMENTS**

The Food Service Advisory Committee has developed a uniform guideline for the sizing of hot water heaters for food service establishments. This guideline is used to insure uniformity on sizing of water heaters throughout the state and to insure food service establishments are provided with sufficient hot water for all operations.

#### **The hot water heater should be sized as follows:**

1. The minimum storage capacity for any establishment should be 50 gallons.
2. Hot water recovery is based on fixture requirements in accordance with the table on the next page.
3. A 100% degree-rise in temperature is used in calculating hot water recovery.

## Hot Water Heater Size And Capacity

### HOT WATER HEATER CALCULATION WORKSHEET

EQUIPMENT	QUANTITY	TIMES	SIZE	EQUALS	GPH
			(in inches)		
One-comp. sink See note #4		<b>X</b>	__by__by__	=	
Two-comp. sink See note #4		<b>X</b>	__by__by__	=	
Three-comp. sink See note #4		<b>X</b>	__by__by__	=	
Four-comp. sink See note #4		<b>X</b>	__by__by__	=	
One-comp Prep sink		<b>X</b>	5 GPH	=	
Two-comp Prep sink		<b>X</b>	10 GPH	=	
Three-comp Prep sink		<b>X</b>	15 GPH	=	
Three comp. bar sink See note #4		<b>X</b>	__by__by__	=	
Four comp. bar sink See note #4		<b>X</b>	__by__by__	=	
Hand sink		<b>X</b>	5 GPH	=	
Pre-rinse		<b>X</b>	45 GPH	=	
Can wash		<b>X</b>	10 GPH	=	
Mop sink		<b>X</b>	5 GPH	=	
**Dishmachine		<b>X</b>	Note #1	=	
**Cloth Washer		<b>X</b>	Note #2	=	
**Hose reels		<b>X</b>	Note #3	=	
Other equipment		<b>X</b>		=	

Other equipment		<b>X</b>		=	
Other equipment		<b>X</b>		=	
Total 140 F GPH (gallons per hour) Recovery Requirements Total =>					
Note - 140° F Hot water heaters are to be sized at the 140° F GPH recovery required at a temperature rise of 100° F.					

Note #1	Dishwasher (____ gals/hr. FINAL RINSE x 70%)
Note #2	<p>Cloth Washer Calculation</p> <p>A. Limited Use/Cloth washer used one to two times per day; beginning or ending of day operation GPH = 60 GPH x 25%.</p> <p>B. Intermediate Use/Cloth washer used three to four times per day; GPH = 60 GPH x 45%.</p> <p>C. Heavy Use/Cloth washer used once every two hours; GPH = 60 GPH x 80%.</p> <p>D. Continuous Use/Cloth washer used every hour; GPH = 60 GPH x 100%.</p>
Note #3	Hose reels @ 20 GPH for first reel & 10 GPH for each additional reel.
Note #4 GPH Requirements for sink	<p><b>GPH = ( Sink size in cu.in. x 7.5 gal./cu.ft. x # compartments x .75 capacity)</b> <b>( 1,728 cu.in./cu.ft.)</b></p>
Short version for above	<p>GPH = Sink size in cu. in. X # compartments x .003255/cu. in.</p> <p>Example 24"x 24"x 14" x 3 compartments x .003255 = 79 GPH</p>
Water heater storage capacity. (____ Gallons Storage)	
Water heater recovery rate in gallons per hour at a 100°F temperature Rise. (____Gallons per hour)	

**SAMPLE CALCULATION**

Three comp. sink -----	1	x	24x24x14	=	79
Two comp. Prep sink ----	2	x	10 GPH	=	20
Hand sink -----	5	x	5 GPH	=	25
Pre-rinse -----	1	x	45 GPH	=	45
Dishmachine -----	1	x	Note #1	=	52
Can wash -----	1	x	10 GPH	=	10
Mop sink -----	1	x	5 GPH	=	5
Cloth Washer -----	1	x	Note #2	=	27
Hose reel -----	2	x	Note #3	=	30
-----					
Total GPH Requirement = 293 GPH					

**Note #1** - Dishmachine - Hobart AM-14 Final Rinse GPH = 74  
 Using Note #1 - 74 gal/hr Final Rinse x .70% = 51.8(= 52 GPH)

**Note #2** - Cloth Washer used 4 times per day = 60 gal x 45% = 27 GPH

## PART 10 - FINISH SCHEDULE

The following chart provides guidance for finishes for floors, walls and ceilings:

	<b>FLOOR</b>	<b>WALL</b>	<b>CEILING</b>
<b><u>KITCHEN</u></b>			
<b><u>COOKING</u></b>	Quarry tile; Poured seamless, sealed concrete	Stainless steel; Aluminum; Ceramic tile	Plastic coated or metal clad fiberboard; Dry-wall epoxy, Glazed surface; Plastic laminate
<b><u>FOOD PREP</u></b>	Same as above plus commercial grade vinyl composition tile.	Same as above plus approved wall panels (FRP) Fiberglass Reinforced Polyester Panel; epoxy painted drywall; filled block with epoxy paint or glazed surface	Same as above
<b><u>BAR</u></b>	Same as above	Same as above for areas behind sinks	Meets building codes
<b><u>FOOD STORAGE</u></b>	Same as above plus sealed concrete; commercial grade vinyl composition tile; or sheets	Approved wall panels (FRP) Fiberglass Reinforced Polyester Panel; epoxy painted drywall; filled block with epoxy paint or glazed surface	Acoustic tile; painted sheetrock
<b><u>OTHER STORAGE</u></b>	Same as above	Painted sheetrock	Same as above
<b><u>TOILET ROOM</u></b>	Quarry tile; poured sealed concrete; commercial grade vinyl composition tile or sheets	Approved wall panels (FRP) Fiberglass Reinforced Polyester Panel; epoxy painted drywall; filled block with epoxy paint or glazed surface	Plastic coated or metal clad fiberboard; dry- wall with epoxy; glazed surface; plastic laminate

	<b>FLOOR</b>	<b>WALL</b>	<b>CEILING</b>
<b><u>DRESSING ROOMS</u></b>	Same as above	Painted sheetrock	Same as above plus painted sheetrock
<b><u>GARBAGE &amp; REFUSE AREAS (Interior)</u></b>	Quarry tile; poured seamless, sealed concrete; commercial grade vinyl composition tile or sheets	Approved wall Panels (FRP) Fiberglass Reinforced Polyester Panel; epoxy painted drywall; filled block with epoxy paint or glazed surface	Plastic coated or metal clad fiberboard; dry-wall with epoxy; glazed surface; plastic laminate
<b><u>MOP SERVICE AREA</u></b>	Quarry tile; poured seamless sealed concrete	Same as above	Same as above
<b><u>WAREWASHING AREA</u></b>	Same as above plus commercial grade vinyl composition tile	Stainless steel; aluminum; approved wall panels (FRP) Fiberglass Reinforced Polyester Panel; epoxy painted drywall; filled block with epoxy paint or glazed surface	Same as above
<b><u>WALK-IN REFRIGERATORS &amp; FREEZERS</u></b>	Quarry tile; stainless steel; poured sealed concrete; poured synthetic	Aluminum; stainless steel; enamel coated steel (or other corrosion resistant material)	Aluminum; stainless steel; enamel coated steel (or other corrosion resistant material)

**Notes:**

FLOORS

1. All floor coverings in food preparation, food storage, utensil-washing areas, walk-in refrigeration units, dressing rooms, locker rooms, toilet rooms and vestibules must be smooth, non-absorbent, easily cleanable and durable. Anti-slip floor covering may be used in high traffic areas only.

2. Any alternate materials not listed in the above chart must be submitted for evaluation.

3. There must be coving at base junctures that is compatible with both wall and floor coverings. The coving should provide at least 1/4 inch radius and 4" in height. See figure #10-1.

4. Properly installed, trapped floor drains shall be provided in floors that are water-flushed for cleaning or that receive discharges of water or other fluid waste from equipment, or in areas where pressure spray methods for cleaning equipment are used. Floors should be sloped to the drain at least 1/8" per foot.
5. Grouting should be non-absorbent and impregnated with epoxy, silicone, polyurethane or equivalent compound.
6. All walk-in refrigeration units, both with prefabricated floors and without, should be installed in accordance with the manufacturers' installation requirements.

## WALLS

1. The walls, including non-supporting partitions, wall coverings and ceilings of walk-in refrigeration units, food preparation areas, equipment washing and utensil washing areas, toilet rooms and vestibules shall be smooth, non-absorbent, and capable of withstanding repeated washing. Light colors are recommended for walls and ceilings. Studs, joists and rafters shall not be exposed in walk-in refrigeration units, food preparation areas, equipment washing and utensil washing areas, toilet rooms and vestibules. Where permitted, exposed studs, joists and rafters must be finished to provide an easily cleanable surface.
2. All alternate materials not listed in the above chart must be submitted for evaluation.
3. Glazed surfaces should be glazed block or brick, or ceramic tile. Grouting must be non-absorbent and impregnated with epoxy, silicone, polyurethane or an equivalent compound. Concrete block, if used, must be rendered non-porous and smooth by the application of an approved block filler followed by the application of an epoxy-type covering or equivalent. All mortar joints shall be only slightly tooled and suitably finished to render them easily cleanable.
4. Plastic laminated panels may find applications but are not recommended.
5. Joint finishes should be compatible with the wall structure. Voids should be eliminated at joints.

## CEILINGS

Finishes shall be light-colored, smooth, non-absorbent and easily cleanable. Acoustical material free of porous cloth or sponge may be used, provided ventilation is adequate to minimize soiling.

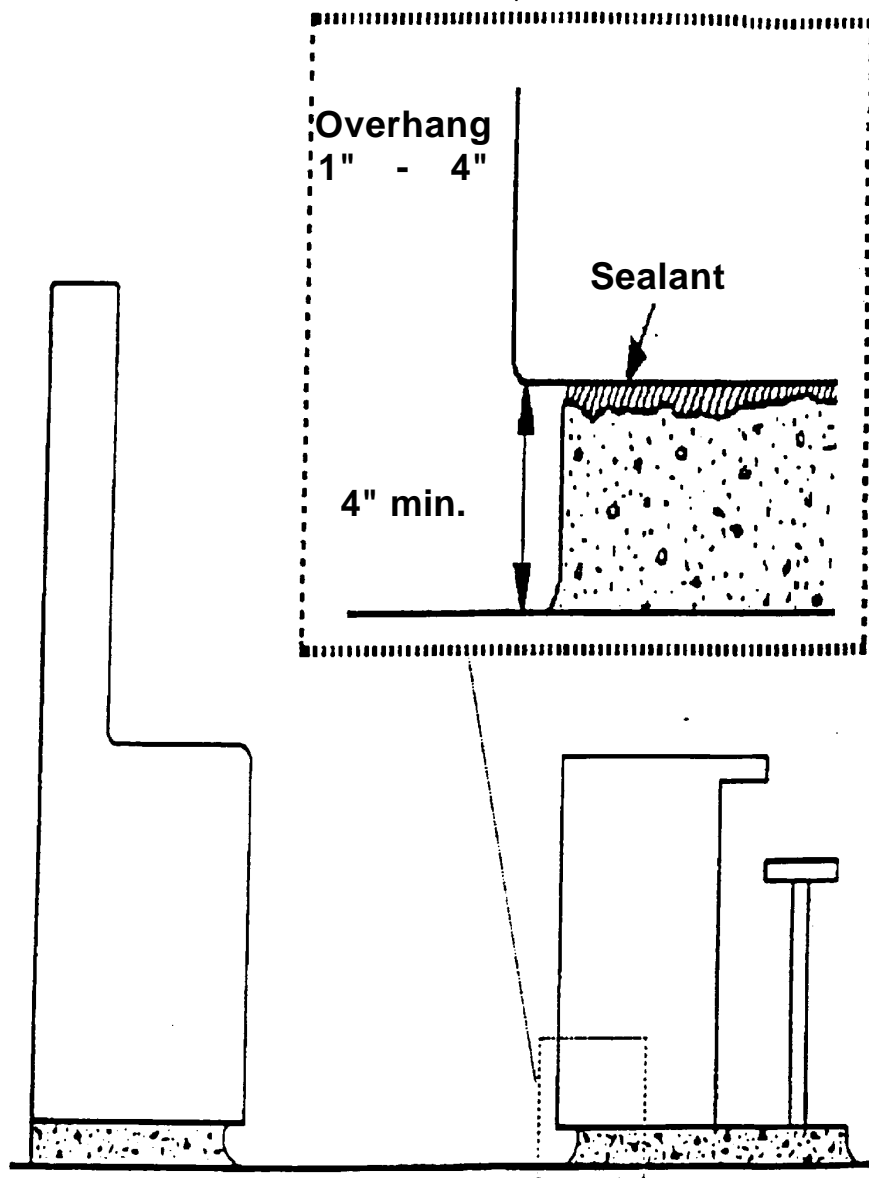

## Coving At Base Junctions

Figure 10-1

## **PART 11 - TOILET FACILITIES**

Toilet facilities shall be installed according to law and shall be the number required by law. They shall be conveniently located and shall be accessible to employees at all times.

Toilets and urinals shall be designed to be easily cleanable and shall have integral backflow prevention devices as required by law.

Toilet rooms shall be completely enclosed and shall have tight fitting, self-closing, doors and should be vented to the outside if subject to odors.

Toilet facilities shall be of adequate number for customers, workers and handicapped. Toilet facilities shall be accessible in accordance with the Americans with Disabilities Act (ADA) of 1990.

## **PART 12 - PLUMBING AND CROSS CONNECTION CONTROL**

Plumbing shall be sized and installed according to applicable codes. There shall be no cross connections between the potable water supply and any nonpotable or questionable water supply. Where nonpotable water systems are permitted for purposes such as air conditioning and fire protection, the nonpotable water must not contact directly or indirectly: food, potable water or equipment that contacts food or utensils. The piping of any nonpotable water system shall be durably identified so that it is readily distinguishable from piping that carries potable water.

### **SUBMERGED INLET PROTECTION**

A cross connection is defined as any connection or structural arrangement between a potable water system and a non-potable source, liquid or otherwise, through which backflow can occur.

Backflow is defined as the flow of water or other liquids, mixtures, or substances into a potable water system from any source, other than the intended source.

A connection to a sewer line may be direct or indirect:

- \* A direct connection is a solid physical joining to a waste or soil line;
- \* An indirect connection is other than a solid physical joining to a waste or soil line (such as a submerged inlet).

An indirect connection may be one of two types:

- \* An air gap means the unobstructed vertical distance through the free atmosphere between the lowest opening from any pipe or outlet supplying fixture, or other device, and the flood level rim of the receptacle. The vertical physical separation shall be at least two times the inside diameter of the water inlet pipe above the flood rim level, but shall not be less than one inch.
- \* An air break is a piping arrangement in which a drain from a fixture, appliance, or device discharges indirectly into another fixture, receptacle or interception at a point below the flood level rim. The connection does not provide an unobstructed vertical distance through the free atmosphere and is not solidly connected, but precludes the possibility of backflow to a potable water source into a sink or dishwasher/or fixture being drained. See figure #12-5.

There shall be no cross connections between the potable water supply and any non-potable

water supply. The potable water system shall be installed to preclude the possibility of back flow and back siphonage. Devices shall be installed to protect against backflow and backsiphonage at all fixtures and equipment unless an air gap is provided. The air gap must be at least twice the diameter of the water supply inlet, but not less than 1", between the water supply inlet and the fixture's flood level rim. See figure #12-1 & 12-2.

The following provides examples of some of the types of equipment with potentially submerged inlets and required backflow/backsiphonage protection:

<u>Equipment</u>	<u>Backflow/Backsiphonage Preventer Required in Lieu of Air Gap</u>
1. Boiler with chemicals added	Reduced pressure device
2. Boiler with no chemicals added	Air vent type backflow preventer
3. Carbonators for beverage dispensers	Approved backflow preventer (in agreement with local plumbing codes)
4. Lawn sprinkler system with no chemicals added	Atmospheric or pressure vacuum breaker
5. Flush valve toilets	Atmospheric or pressure vacuum breaker
6. All hose bibs inside & outside of establishments	Hose bib-type vacuum breaker
7. Preflush hose with a nozzle head that may be submerged	Pressure vacuum breaker
8. Perforated pipe to oriental wok cookers	Atmospheric vacuum breaker
9. Inlets which are or may become submerged:	
a. Supply inlet to garbage grinder	Atmospheric vacuum breaker*
b. Supply inlet to dish table trough	"      "      "
c. Fill line for steam kettle	"      "      "

Backflow/Backsiphonage Preventer

Equipment

Required in Lieu of Air Gap

d. Supply line for mechanical warewashing machine	"	"	"
e. Supply line to all soap and chemical dispensing units on mechanical warewashing machine.	"	"	"
f. Garbage can washer	"	"	"
g. Soap portioner on faucet	Soap portioner must contain an internal air gap		
h. Water wash system for exhaust hood	Air vent type backflow preventer (RPZ may be required if toxic chemicals are added)		

See figure #12-3 for examples of backflow/backsiphonage prevention devices.

\*An atmospheric vacuum breaker means a mechanical device which automatically air vents a pipeline to prevent backsiphonage. The device shall be located beyond the last control valve prior to the first outlet and at an elevation 6 inches higher than any source of contamination. Atmospheric vacuum breakers shall be installed so that they are not subject to backpressure or continuous operating pressure of more than 12 hours duration.

DRAINS

A direct connection may not exist between the sewerage system and any drains originating from equipment in which food, portable equipment, or utensils are placed, except if otherwise required by state plumbing codes. When a warewashing machine is located within 5 feet of a trapped floor drain, the dishwasher waste outlet may be connected directly on the inlet side of a properly vented floor drain trap. See figure #12-4.

Other examples of required indirect drain line connections are:

<u>Equipment</u>	<u>Required Indirect Drain Line Connection to Sewer Line</u>
1. Water-cooled condenser for ice machine or other refrigeration system	Air gap
2. Air-cooled condenser for ice machine or other refrigeration system	Air break
3. Ice bin	Air break

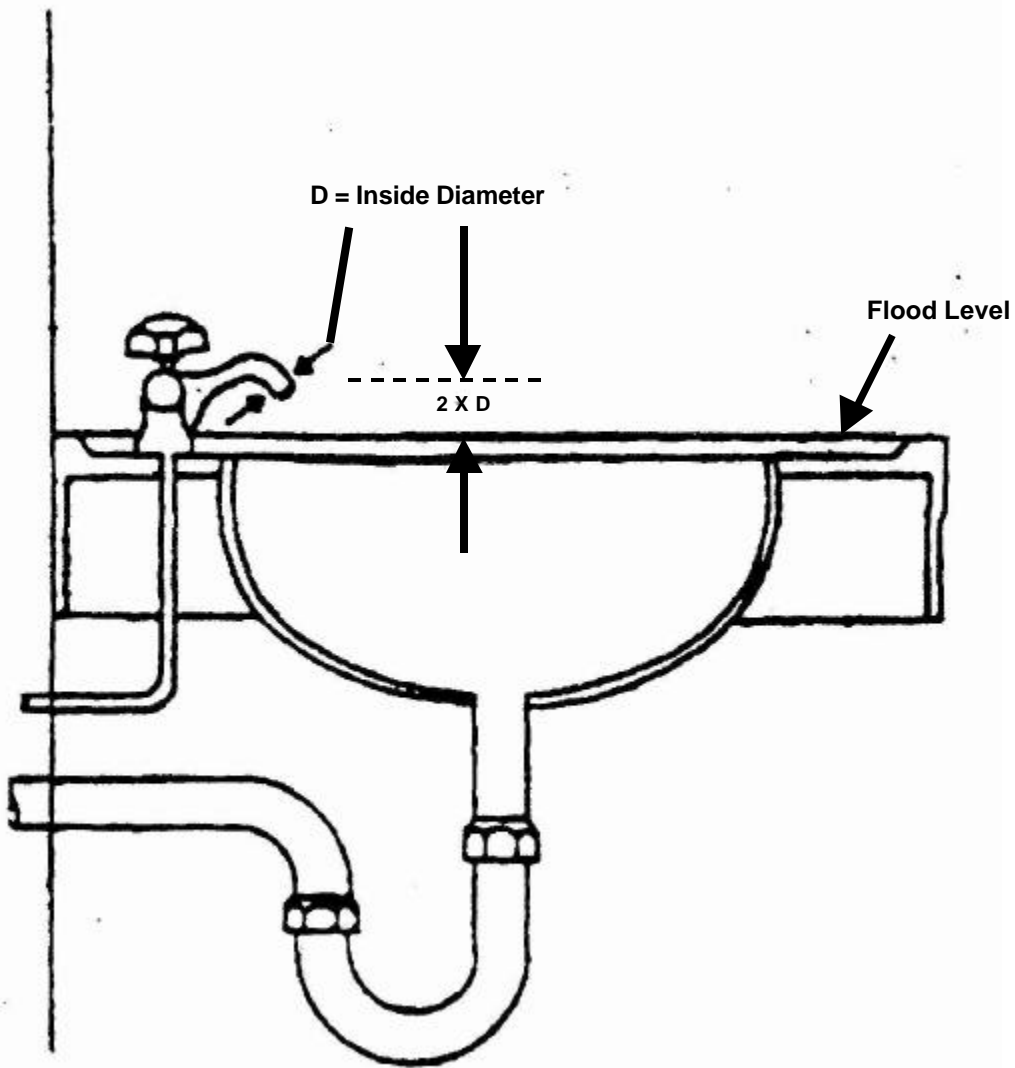

## Air Gap On Lavatory

Figure 12-1

D= Inside Diameter

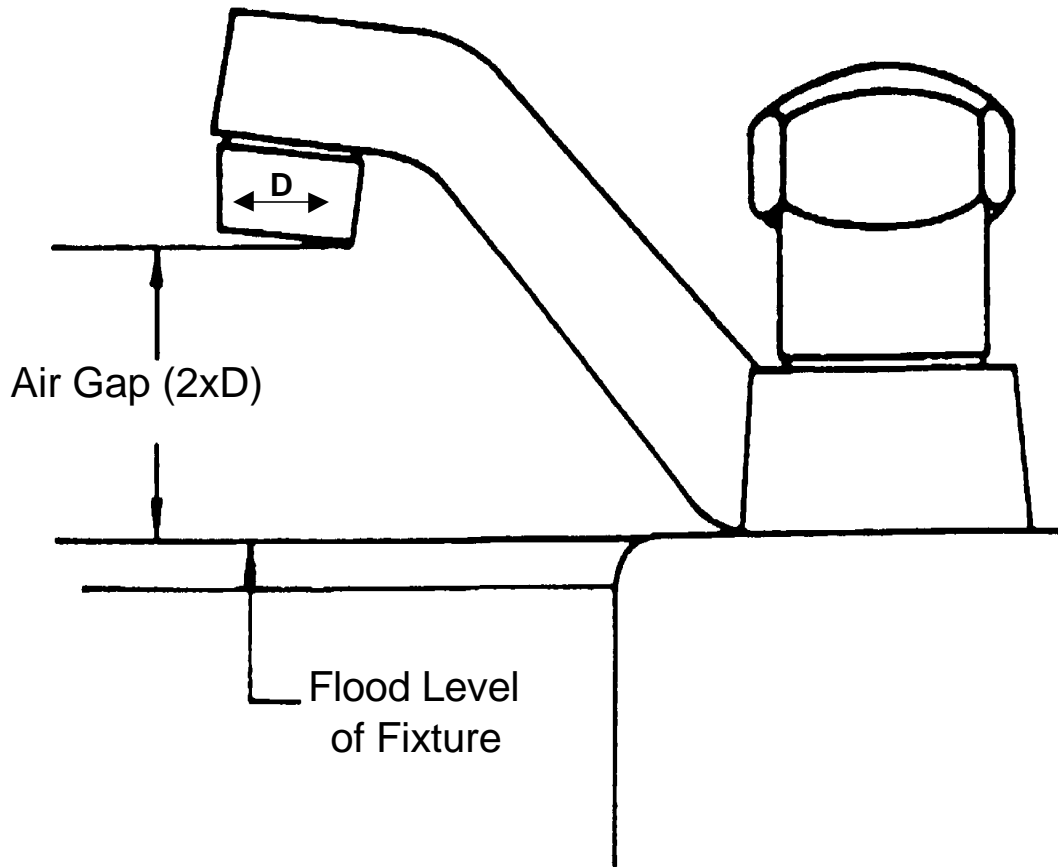

## Air Gap And Effective Opening

Figure 12-2

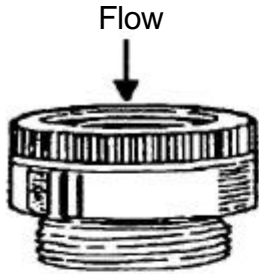

Hose Bibb Vacuum Breaker



Atmospheric Vacuum Breaker

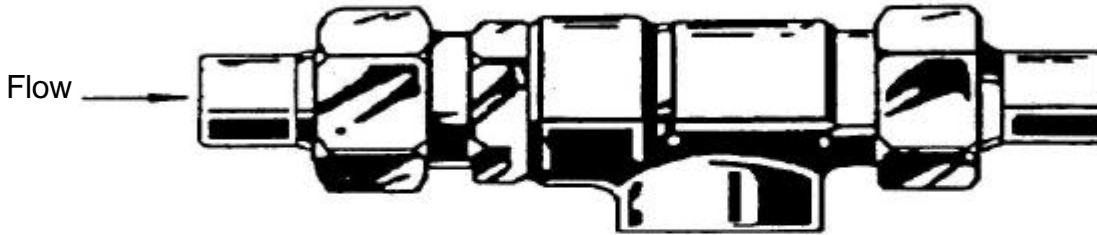

Backflow Preventer with Intermediate Vent

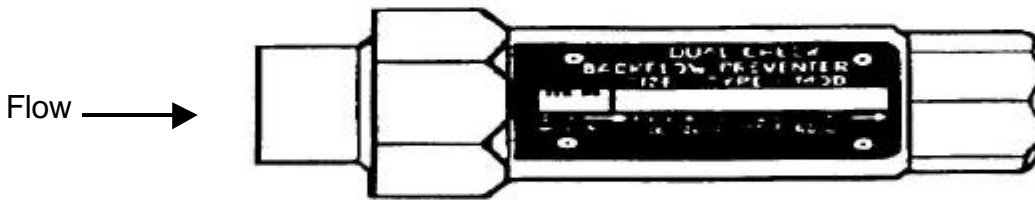

Dual Check Backflow Preventer



Carbonator Backflow Prevention

## Backflow Prevention Devices

Figure 12-3

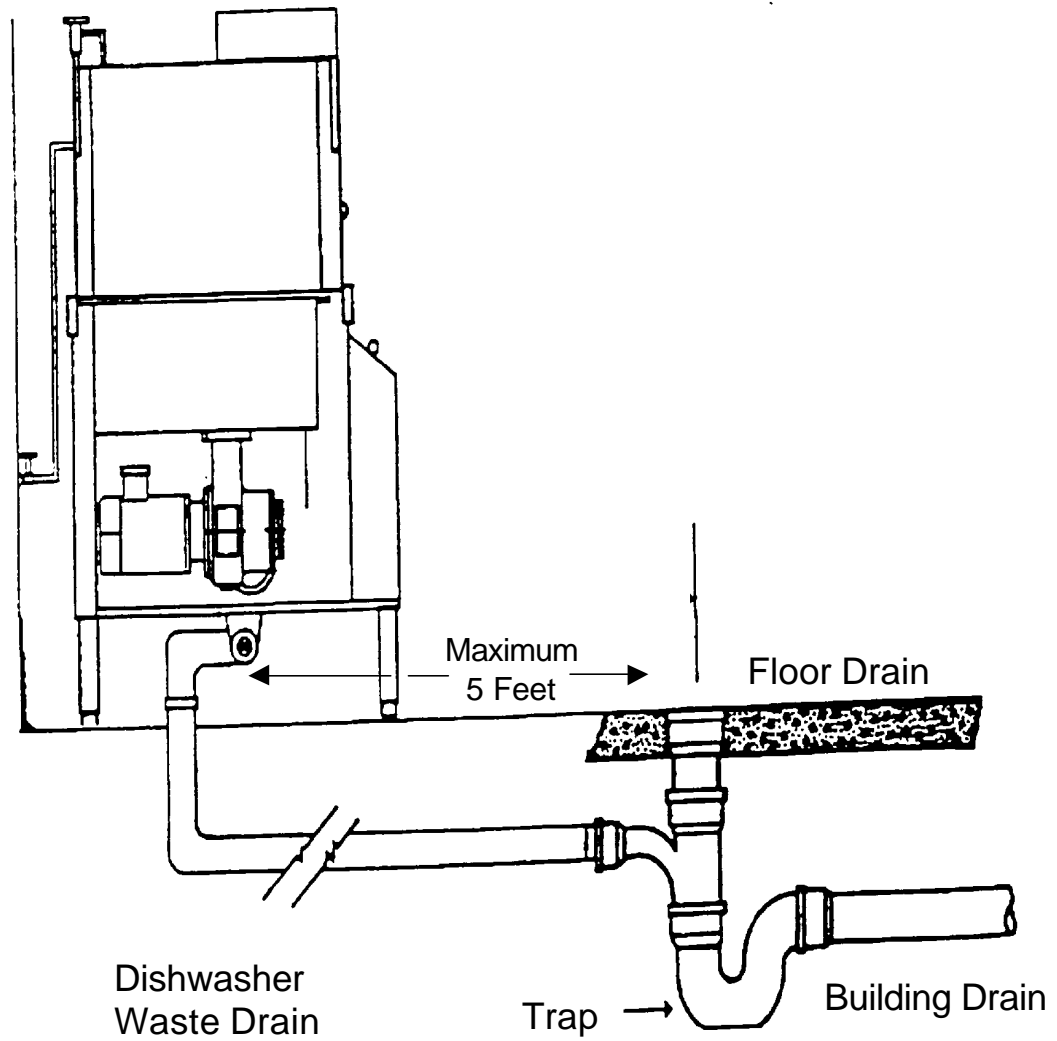

## Warewashing Machine With A Direct Waste Connection

Figure 12-4

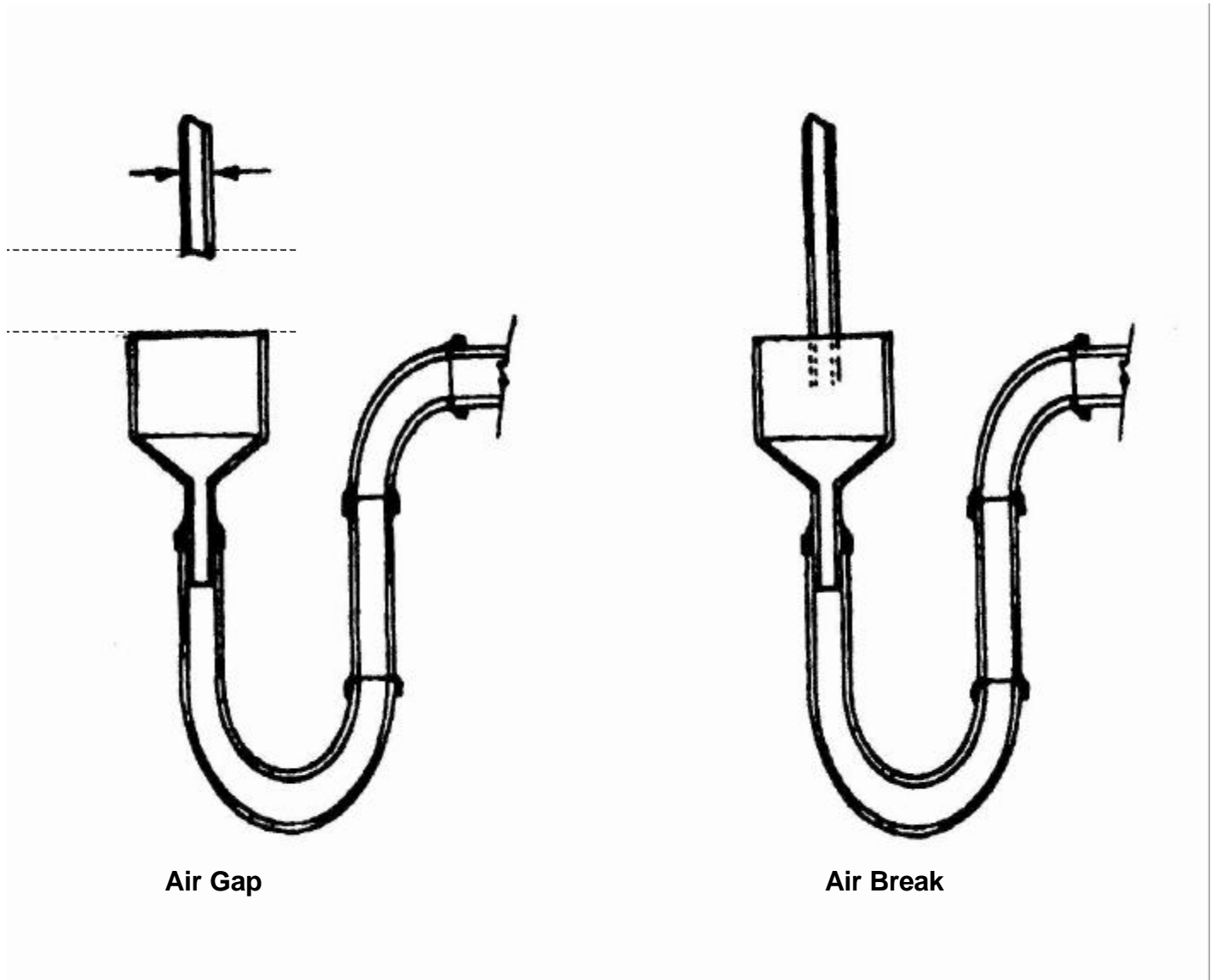

## Indirect Waste

Figure 12-5

### **PART 13 - INSECT AND RODENT CONTROL**

Openings to the outside shall be effectively protected against the entrance of rodents. Openings to the outside shall be protected against the entrance of insects by the installation of tight fitting, self-closing doors; closed windows; self-closing serving windows at drive-throughs; screening; controlled air currents; vestibules; or other means approved by the regulatory health authority. Screen doors shall be self-closing and screens for windows, doors, skylights, transoms, intake air ducts and other openings to the outside shall be tight fitting and free of breaks. Screening material shall not be less than sixteen mesh to the inch. Openings around pipes, conduit or wiring entering the building from the outside must be sealed.

Loading docks and delivery doors must be provided with effective air curtains or vestibules with self-closing doors to preclude the entrance of insects. It is recommended that outside lighting around loading areas and entrances be sodium vapor rather than mercury vapor to decrease insect attraction.

All foundations shall be rodent proof. Openings between the floor and bottom of outer doors shall be adequately flashed with rodent proof material to eliminate any opening.

## **PART 14 - LIGHTING**

The light intensity shall be at least 110 lux (10 foot candles) at a distance of 75 cm (30 inches) above the floor, in walk-in refrigeration units and dry food storage areas and in other areas and rooms during periods of cleaning.

The light intensity shall be at least 220 lux (20 foot candles) at a surface where food is provided for consumer self-service such as buffets and salad bars or where fresh produce or packaged foods are sold or offered for consumption; inside equipment such as reach-in and under-counter refrigerators; at a distance of 75 cm (30 inches) above the floor in areas used for handwashing, warewashing, and equipment and utensil storage, and in toilet rooms.

The light intensity shall be at least 540 lux (50 foot candles) at a surface where a food employee is working with food or working with utensils or equipment such as knives, slicers, grinders, or saws where employees safety is a factor.

Darker colored walls and floors may require additional lighting.

Shielding such as plastic shields, plastic sleeves with end caps, shatterproof bulbs and/or other approved devices shall be provided for all artificial lighting fixtures located in areas where there is exposed food; clean equipment, utensils, and linens; or unwrapped single-service and single-use articles.

Heat lamps, where permitted, shall be protected against breakage by a shield surrounding and extending beyond the bulb, leaving only the face of the bulb exposed.

## **PART 15 - VENTILATION**

### **GENERAL**

All rooms shall have sufficient ventilation to keep them free of excessive heat, steam, condensation, vapors, obnoxious odors, smoke and fumes. Ventilation systems shall be designed and installed according to law.

All hoods should be tested prior to use, to ensure the hoods exhaust adequately.

Lighting within the hood may be required to comply with state or local code requirements. If laundry dryers are used they should be vented to the outside.

### **COOKING**

Cooking ventilation hoods and devices shall be designed and installed to prevent grease or condensation from collecting on walls, ceilings, and fire suppression supply piping and from dripping into food or onto food contact surfaces. See figure #15-1.

All hoods shall comply with the standards of an ANSI accredited certification program and be designed, constructed and installed in conformance with the National Fire Protection Association Bulletin #96 (The Standard for Ventilation Control and Fire Protection of Commercial Cooking Operations), and other applicable fire safety codes.

Make up air intakes must be screened (bird screen) and filtered to prevent the entrance of dust, dirt, insects and other contaminating material. Where the introduction of make up air will cause condensation, drafting or interfere with the exhaust or vapor capture efficiency of the hood, the make up air must be tempered. A make up air system will be required if the exhaust is greater than 1500 cfm. Tempering of makeup air may be necessary in certain climates.

The installation of fire suppression system piping in the unfiltered air space in exhaust hoods should be limited to vertical runs as much as physically possible to minimize grease collection. Exposed piping must be cleanable.

### **HOT WATER SANITIZING DISHMACHINES**

Hot water sanitizing dishwashing machines must be provided with adequate ventilation sized according to the dishwashing machine manufacturer's specifications.

---

The following information is provided to offer guidance in meeting the requirement for ventilating cooking equipment. There are several methods used in calculating the volume of air movement, measured in Cubic Feet per Minute (CFM), necessary to effectively and efficiently ventilate cooking equipment. While these methods are used in general applications, it must be noted that engineered exhaust systems which are customized for specific equipment under specific use conditions may also be approved by the building code official or fire marshall.

### **General Principles of Exhaust**

The purpose of an exhaust hood is to provide a method of collecting, as nearly as possible, all of the grease produced from the cooking process, while furnishing a means of removing heat, smoke, and odors from the cooking area.

For the hood to fulfill its purpose there must be a sufficient volume of air movement (capture velocity) to draw grease particles and cooking vapors directly from the cooking surface to the grease extractors. This air flow removes cooking odors and keeps grease particles from settling onto nearby surfaces.

An effective capture velocity shall be sufficient to overcome opposing air currents, capture the grease and cooking vapors, and transport them directly to the grease extractors.

Grease extractors are ineffective in removing grease vapors. Only when grease vapors cool and condense can an extractor remove grease particles by directed air flow, contraction, and expansion (drop out). It is essential to have a sufficient volume of air flowing to cool and condense the grease vapors into grease particles prior to reaching the grease extractors.

Non-toxic smoke bombs may be used to evaluate and regulate kitchen exhaust hoods and supply systems. No fabricator of exhaust hoods can create all the conditions in the plant that the hood must cope with on the job site to function correctly.

In the case of heat and steam producing equipment, the purpose of the hood or ventilation system (such as a pants-leg duct system) is to control humidity, heat, and unwanted condensation.

A major cause of unacceptable hood performance is a lack of coordination between the Heating, Ventilation, and Air Conditioning (HVAC) system and the exhaust hood system. These systems should be coordinated prior to installation, and balanced when installation is completed, to ensure the proper performance of both.

## Fire Protection

Exhaust ventilation systems for all grease producing cooking equipment is under the jurisdiction of the State Fire Marshal's Office and local fire and building officials. System designers and/or owners should contact these officials regarding fire safety plan review and inspection.

## Hood Size

1. Canopy hoods and island hoods shall have a minimum depth of two feet and shall extend at least six inches beyond any equipment being ventilated, except that no overhang will be required on sides where aprons are installed. The dimensions of the hood are, in all cases, larger than the cooking surface to be covered by the hood. The amount of overhang of the hood depends upon the clearance or distance between the base of the hood and the top of the cooking equipment. A rule of thumb for the overhang on canopy hoods is 0.4 of the distance from the cooking surface to the bottom of the hood, but in any case, no less than six inches.

### **Example:**

Hood overhang = distance from bottom of hood to top of range =  $0.4 \times 3.25 \text{ ft.} = 1.30 \text{ ft.}$ , or approximately 1 foot, 4 inches

Canopy hoods shall be installed so that the bottom of the hood is between 6.5 feet and 7 feet above the finished floor.

**(Figure 15-1 illustrates a canopy hood.)**

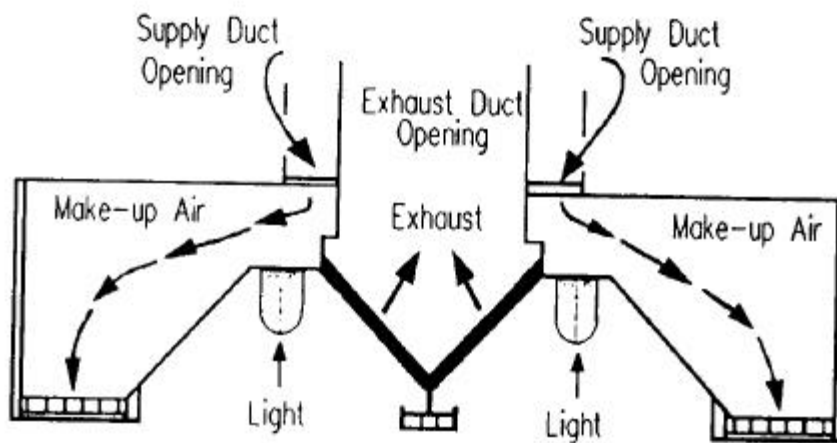
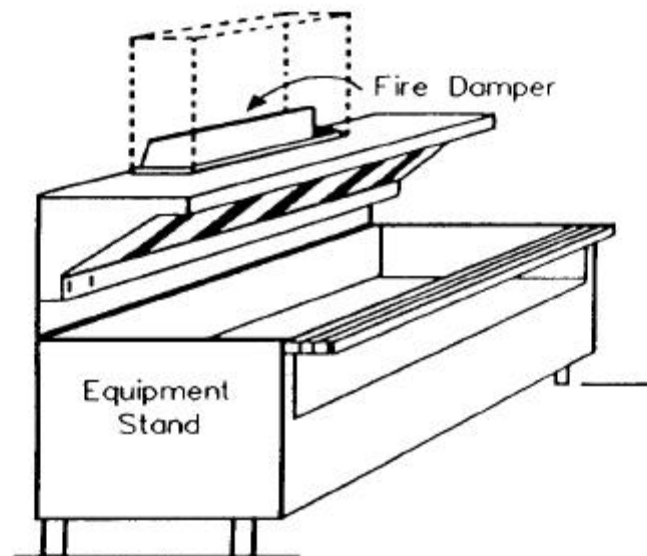

**FIGURE 15-1**

2. Ventilator, or "backshelf", hoods are designed to mount to the wall directly behind the cooking equipment. This type of hood is often used where ceiling height is a factor. It is normally placed closer to the cooking surfaces than a canopy hood, and works well in light to medium duty cooking applications. The ventilator hood is not recommended for charbroilers or similar high heat and grease producing cooking equipment. It does not have the capture area of a canopy hood and is not able to effectively handle large surges of cooking emissions (steam, heat, vapors, etc.)

Several dimensions are essential in the proper installation of a ventilator hood. Ventilator hoods shall extend from the wall a minimum of 16 inches, and shall be installed so that the distance from the top of the cooking equipment to the bottom of the ventilator hood is no more than 24 inches. Equipment placed under a ventilator hood shall not extend beyond the sides of the hood or more than 36 inches from the back of the hood. These restrictions are necessary to ensure maximum capture and removal of cooking emissions.

**(Figure 15-2 illustrates a ventilator hood.)**



**FIGURE 15-2**

3. Pants-leg exhaust systems are designed to remove the heat or steam close to the point of discharge from warewashers or conveyor cooking equipment. These systems must be sized to effectively ventilate the equipment served.

**(Figure 15-3 illustrates a pants-leg duct system.)**

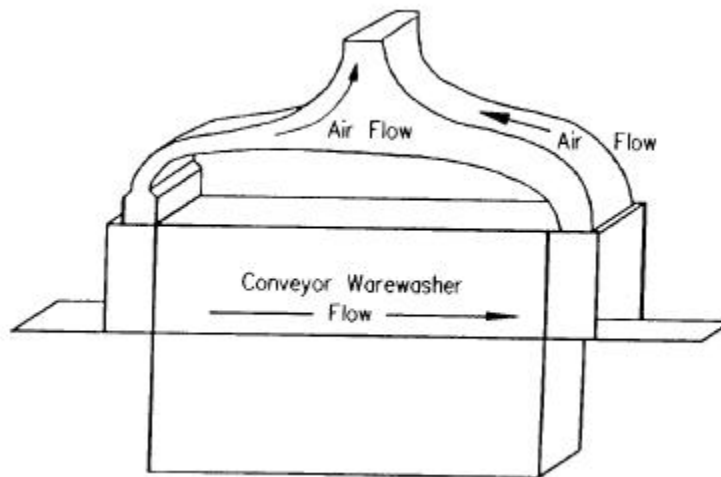

**FIGURE 15-3**

4. Eyebrow hoods are designed to immediately remove heat from an oven at the point of emission or as the door is opened. These hoods must effectively ventilate the door openings of the equipment served.

**(Figure 15-4 illustrates an eyebrow hood.)**



**FIGURE 15-4**

## Exhausted Air

The amount of air exhausted through a hood exhaust system is dependent upon the size of the hood, its particular installation, and its use. There are several methods available for determining the amount of air to be exhausted. With the exception of systems engineered for specific equipment and specific applications that are approved by the health authority, the following criteria shall be used to calculate the amount of air exhausted:

1. Canopy hoods.

A. Standard square foot method.

This method of calculating exhaust air volume is based on the size of the opening in the hood (length x width) and the capture velocity relative to the installation of the hood (see Table I).

Hood length x hood width = square feet (ft.<sup>2</sup>) of hood opening.

Ft.<sup>2</sup> of hood opening x factor from Table I = CFM of air exhausted.

**TABLE I.**

<u>Exposed sides</u>	<u>Factor(CFM/ft.<sup>2</sup>)</u>
4 (central island hood)	125
3 (wall hung hood)	100
2 (corner hung hood, or with aprons)	85
Steam or heat exhaust only	70

### **Example:**

8 ft. (length) x 4 ft. (width) = 32 ft.<sup>2</sup>

32 ft.<sup>2</sup> X 100 CFM/ft.<sup>2</sup> (wall hung hood) = 3200 CFM

B. Exposed linear foot method.

This method of calculating the exhaust air volume is based on the total exposed linear footage of the hood and the capture velocity relative to its application (see Table II).

Exposed linear footage of hood x factor from Table II = CFM of air exhausted.

**TABLE II**

Application Factor (CFM/in. ft.)

Light duty (no grease, light grease)	150 - 250
Medium duty (fryers and griddles)	250 - 350
Heavy duty (heavy grease, charbroiler)	350+

**Example:**

4 ft. x 8 ft. hood (light grease), 3 exposed sides

4 ft. + 8 ft. + 4 ft. = 16 exposed linear ft.

16 exposed linear ft. x 250 CFM/linear ft. = 4000 CFM

**C. Square feet of cooking surface method.**

This calculation of the volume of exhausted air depends on the size, temperature, and design of the cooking equipment and the minimal capture velocity required to keep smoke, vapors, and fumes under the hood. The amount of air to be removed is calculated by multiplying the surface area of the equipment (f t.<sup>2</sup>) by the appropriate updraft velocity factor (see Table III); total air exhausted is the sum of exhaust air volumes of all the equipment added to the minimal capture velocity.

Ft.<sup>2</sup> of cooking surface of each piece of equipment (length x width) x the updraft velocity factor from Table III = CFM of exhaust required for each piece of equipment.

**TABLE III.**

Application	Updraft velocity factor
Steam kettles, ranges, ovens, non-grease producing equipment	50 fpm
Fryers/griddles, grease Producing equipment	85 fpm
Charbroilers, high heat and grease producing equipment	150 fpm

**Example:**

<u>Equipment</u>	<u>Square feet</u>
oven	30" x 36" = 7.5 ft. <sup>2</sup>
fryer	18" x 24" = 3.0 ft. <sup>2</sup>
charbroiler	32" x 54" = 7.6 ft. <sup>2</sup>
range	42" x 34" = 9.6 ft. <sup>2</sup>

<u>Ft.</u>		<u>Factor</u>	<u>Exhaust</u>
7.5	X	50 fpm	375 CFM
3.0	X	85 fpm	255 CFM
7.6	X	150 fpm	1140 CFM
9.6	X	85 fpm	816 CFM
Total equipment exhaust volume =			2586 CFM

The minimal capture velocity = [hood opening area (ft.<sup>2</sup>) - cooking equipment surface area (ft.<sup>2</sup>) x 50 fpm]

**Example:**

4 ft. x 15 ft. hood = 4 ft. x 15 ft. = 60 ft.<sup>2</sup> hood opening

Cooking equipment surface area (from above) = 7.5 ft.<sup>2</sup> + 3 ft.<sup>2</sup> + 7.6 ft.<sup>2</sup> + 9.9 ft.<sup>2</sup>  
= 28 ft.<sup>2</sup>

Minimal capture velocity = (60 ft.<sup>2</sup> - 28 ft.<sup>2</sup>) x 50 fpm = 32 ft.<sup>2</sup> x 50 fpm = 1600 CFM

Total system exhaust volume = equipment exhaust volume + minimal capture velocity

**Example:**

Total system exhaust volume = 2586 CFM (from above) + 1600 CFM (from above) = 4186 CFM

Ventilator and backshelf hoods.

Linear footage of hood x ventilator exhaust factor from Table IV = CFM of air exhausted.

**TABLE IV.**

<u>Application</u>	<u>Exhaust Factor</u>
Light duty (non-grease producing)	200 CFM/ft.
Medium duty (light grease producing)	275 CFM/ft.

Heavy duty (heavy grease producing)

350 CFM/ft.

**Example:**

12 ft. ventilator hood, medium duty (light grease producing)  
12 ft. x 275 CFM/ft. = 3300 CFM air exhausted

**Duct Location and Size**

Exhaust ducts should never be located at the sides of the hood. For hoods that are six feet or less in length, only one outlet should be provided. Long hoods should be provided with multiple outlets no closer than six feet apart and no further than 12 feet apart. For hoods equipped with multiple ducts, it is advisable to install a manual air volume damper on each outlet so that the system can be easily balanced.

A duct velocity of no less than 1500 fpm shall be provided to maintain suitable conditions in the duct work. In some cases, a greater duct velocity (i.e. 1800-2200 fpm) may be necessary for the system to function at its best. The cross-sectional area of the exhaust duct (in ft.<sup>2</sup>) can be calculated by using the following formula:

$$\text{Duct area required (ft.}^2\text{)} = \text{Volume of air exhausted (CFM)} \div \text{Duct velocity (fpm)}$$

**Example:**

$$\text{Duct area required (ft.}^2\text{)} = 3000 \text{ CFM} \div 1500 \text{ fpm} = 2 \text{ ft.}^2$$

The area of round duct can be determined from Table V.

**TABLE V.**

Sizing Chart for Round Duct

<b>Duct</b>	<b>Duct Area</b>	
<b><u>Diameter</u></b>	<b><u>(In.<sup>2</sup>)</u></b>	<b><u>(Ft.<sup>2</sup>)</u></b>
10 inches	78.54	.545
12 inches	113.1	.785
13 inches	132.7	.921
14 inches	153.91	.1069
15 inches	176.71	.227
16 inches	201.01	.396
18 inches	254.41	.767
19 inches	283.51	.969
20 inches	314.12	1.182
21 inches	346.32	1.405
22 inches	380.12	1.640
24 inches	452.33	2.142



Once removed, the grease is drained into a collection container in the hood or elsewhere. Extractors have generally replaced wire mesh filters where grease removal is of prime concern and compliance with National Fire Protection Association (NFPA) codes is required. Wire mesh filters may be used to exhaust pizza ovens, bread and pastry ovens, and other similar equipment where grease is not of prime concern. Both wire mesh and extractor type filters have an efficient operating velocity range of 200 to 500 fpm; the operating velocity of the filters shall not be less than 200 fpm.

### **Grease Filter Area and Number of Grease Filters Required**

There are two general types of grease filters: wire mesh and extractor filters. The extractor filter removes grease in the exhaust process by centrifugal motion or by impingement on a series of baffles. The manufacturer's optimum rating of the filter should be used in calculating the filter area required in the exhaust system. Standard size filters should be used to avoid additional cost and to allow ease of replacement. Any space in the filter bank not covered by filters/extractors shall be fitted with sheet metal blanks. If calculations indicate that a fraction of a filter is needed, add an additional filter. The filter area required for an exhaust system can be calculated by using the following formula:

Filter area needed (ft.<sup>2</sup>) = Volume of air exhausted (CFM ) operating velocity of the filters (fpm)

#### **Example:**

Filter area needed (ft.<sup>2</sup>) = 3200 CFM ) 500 fpm = 6.4 ft.<sup>2</sup>

Filters are sized and made removable so that they may be passed through a warewashing machine or cleaned under a steam jet. Standard size grease filters are:

12 inches x 16 inches  
16 inches x 20 inches  
16 inches x 25 inches  
20 inches x 20 inches  
20 inches x 25 inches

The following example illustrates how to determine the number and size of filters needed.

#### **Example:**

1 ft.<sup>2</sup> = 144 in.<sup>2</sup>; a 16 in. x 20 in. filter = 320 in.<sup>2</sup>

320 in.<sup>2</sup> ) 144 in.<sup>2</sup> = 2.22 ft.<sup>2</sup>

3 filters of 16 in. x 20 in. = 6.66 ft.<sup>2</sup>; therefore, 3 filters of 16 in. x 20 in. will meet the filter area requirement of 6.4 ft.<sup>2</sup> calculated in the previous example.

## Calculating Static Pressure

To select the proper size fan, the volume of air to be moved and the total resistance to its movement must be known. There are a number of restrictions in an exhaust system which affect air flow. The resistance to air movement is measured in inches of water, and this friction loss is called static pressure (S.P.).

The static pressure against which the exhaust fan must work is considered to be the sum of the following five items:

1. The resistance of the grease filters measured under heavy use. A value of .2 inches of water is ample for most filters.
2. The "entrance loss" of static pressure occurring where the exhaust duct attaches to the hood will be about .1 inch of water.
3. The resistance created by natural winds blowing on the exhaust duct opening is a matter of judgement; the average wind pressure is approximately .15 inches of water.
4. The energy, or accelerating pressure, required to accelerate the air to the duct velocity, usually about .20 inches of water.
5. The resistance of the exhaust ducting, which is determined by the total length of the straight duct plus the number and type of elbows.

The values used to determine the static pressure that a fan must overcome are specified in Table VI.

**TABLE VI.**

Type of resistance	Amount of resistance
filter	.20 inches
hood entrance loss	.10 inches
wind pressure	.15 inches
accelerating pressure	.20 inches

### **DUCT RESISTANCE**

straight duct = .0025 inches per linear ft.

angles = 90° .20 inches each  
          45° .10 inches each  
          30° .05 inches each

**Example:** An exhaust hood with a straight duct of 8 feet with two 45° elbows

Static Pressure		
Duct (8 ft. x .0025)	=	.02 inches
Elbows (2 x .10)	=	.20 inches
Filter resistance	=	.20 inches
Hood entrance loss	=	.10 inches
Wind pressure	=	.15 inches
<u>Accelerating pressure</u>	=	<u>.20 inches</u>
Total	=	.87 inches

### **Fan Size**

The exhaust fan shall be sized to remove the amount of air to be exhausted at the required static pressure.

### **Make-up Air**

The term "make-up air" is used to identify the supply of outdoor air to a room or building to replace the air removed by an exhaust system. For a consistent and regulated flow, make-up air should be mechanically introduced by a fan, swamp cooler, etc. Mechanically introduced make-up air shall be supplied as part of the exhaust system when the amount of air to be exhausted exceeds 1500 CFM.

Make-up air is critical to the design of a ventilation system. It is generally recognized that all systems exhausting more than 1500 CFM need mechanically introduced make-up air to ensure a balanced system. Mechanical engineers recommend that make-up air be supplied at 85 to 90 percent of the exhausted air. Make-up air controls should be interlocked with exhaust controls to ensure that the units operate simultaneously. Replacement air shall be filtered and may also be tempered by a separate control. The air velocity through the make-up air system should be low enough to avoid the possibility of drafts. It is desirable to have the kitchen under a very slight negative pressure to prevent any filtration of cooking odors from the kitchen into the dining room. The supply of make-up air is frequently introduced at some point within the hood, or in close proximity to the hood, to avoid the removal of conditioned air that has been heated or cooled.

The make-up air inlet should be located at least 10 feet from the exhaust fan to comply with National Fire Protection Association requirements.

Air conditioning may also serve as a source of make-up air, with each ton of an air conditioning system supplying 400 CFM of outside air.

Reference: South Carolina Department of Health And Environmental Control, 2600 Bull Street, Columbia, South Carolina 29201, "Food Equipment Installation Manual"

---

Other references are available for additional formulas and information. Such references include: North American Association of Food Equipment Manufactures. An Introduction to the Food Service Industry. First Edition 1995.

National Environmental Health Association. Manual of Recommended Practice for Ventilation in Food Service Establishments, by James D. Barnes.

## **PART 16 - UTILITY FACILITY**

At least one utility sink or curbed cleaning facility with a floor drain shall be provided for cleaning mops and for the disposal of mop water or similar liquid wastes.

The water supply must be properly protected against backsiphonage.

A properly sized mop and broom rack shall be provided.

All toxic materials including cleaning compounds, pesticides, sanitizers, etc. must be stored in a area away from food preparation. See figure #16-1.

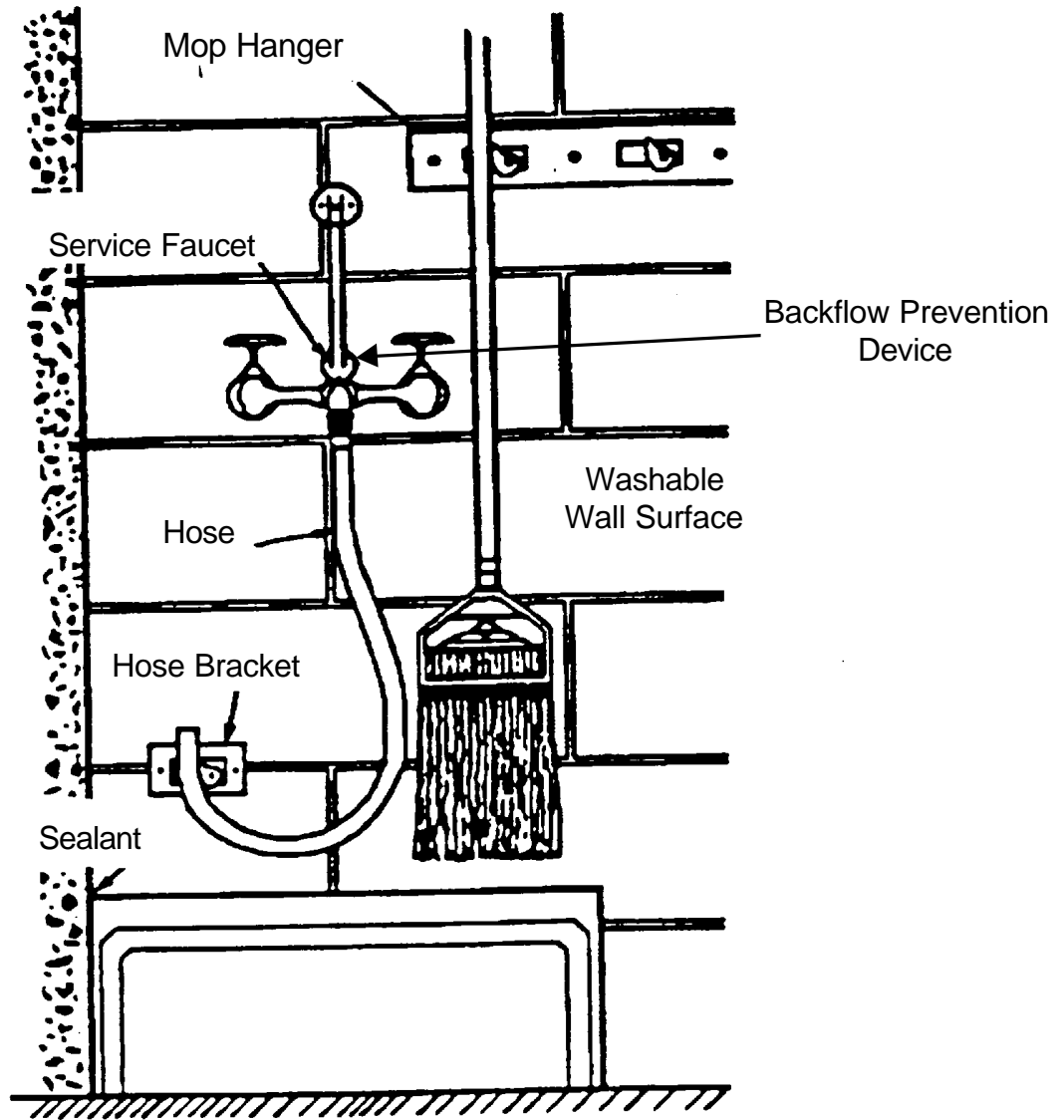

## Utility Facility

Figure 16-1

## **PART 17 - DRESSING ROOMS AND LOCKERS**

Rooms or areas separate from food preparation, storage or service areas, and separate from utensil washing or storage areas should be provided if employees will routinely change clothes within the establishment.

Lockers or other suitable storage facilities shall be located in dressing areas.

If dressing rooms are not required, separate facilities should be provided for the storage of coats, sweaters and other personal belongings.

## **PART 18 - GARBAGE AND REFUSE STORAGE**

Garbage or refuse storage rooms shall be constructed of cleanable, nonabsorbent, washable materials and shall be insect-proof and rodent-proof.

Garbage and refuse containers, dumpsters, and compactor systems located outside shall be stored on or above a smooth surface made of, or constructed of nonabsorbent material such as 4" sealed concrete.

Garbage and refuse containers must have tight-fitting lids or covers.



## EXAMPLE FACILITY FLOOR PLAN



### Equipment (make and model #)

- |  |  |   |
|--|--|---|
| 1. Cheese Melter (ABC #123)  | 16. Shelving Unit                              | 32. Stainless prep table  |
| 2. Microwave (XYZ #34)   | 17. Bread Shelving Racks                       | 33. Walk-in cooler (COLD #AZ1)  |
| 3. Steamtable (HOT #A1)  | 18. Dining Area                                | 34. Walk-in freezer (COLD #AZ3)   |
| 4. Stove (AOK #22)   | 19. Coffee maker (ABC #16)                     | 35. Drying Shelf  |
| 5. Griddle (AOK #Q17)  | 20. Tea Maker (ABC #87)                        | 36. Clean drainboard  |
| 6. Fryer (ABC #55)   | 21. Soda Machine (PDQ #2A)                     | 37. Dishmachine (Magic #15)   |
| 7. Fryer (ABC #55)   | 22. Espresso Machine (ABC #5)                  | 38. Hood, type II (Ezair #17)   |
| 8. Charbroiler (HOT #A7)   | 23. Undercounter Refrigeration Unit (COLD #A3) | 39. Dirty drainboard w/ sprayhose, & garbage disposal   |
| 9. Handsink  | 24. Bakers Table                               | 40. Dirty dish rack   |
| 10. Hood, type I (Ezair #99)   | 25. Bakers Table                               | 41. Drying shelf  |
| 11. Refrigerator/freezer Maketable unit with pass thru and shelf. (Cold #10) | 26. Shelving Unit                              | 42. 3-comp. sink w/ 36" drainboards   |
| 12. Stainless Steel Table  | 27. Bake Oven (JAM #33)                        | 43. Mop sink  |
| 13. Sliding 3 door Refrigeration unit (Cold #12)                             | 28. Hood, type II (Ezair #35)                  | 44. Chemical storage shelf  |
| 14. Shelving unit  | 29. Proof Cabinet (ABC #T2)                    | 45. Shelving  |
| 15. Mixer (XYZ #q23)   | 30. Proof Cabinet (ABC #T2)                    | <div style="display: flex; align-items: center;"> <div style="width: 10px; height: 10px; border: 1px solid black; margin-right: 5px;"></div> <span>Floor Sink</span> </div> <div style="display: flex; align-items: center;"> <div style="width: 10px; height: 10px; border: 1px solid black; border-radius: 50%; margin-right: 5px; margin-left: 20px;"></div> <span>Floor Drain</span> </div> |
|  | 31. Vegetable Prepsink & 18" drainboard        |   |



## REFERENCES

The following is a list of reference materials that users of the Plan Review Guide may find useful to more fully understand the complexities of facility plan review. These references contain suggested formulas in addition to the ones included in the preceding plan review guide.

- Baraban, Regina S. and Joseph F. Durocher, Successful Restaurant Design, New York, NY: Van Nostrand Reinhold.
- Barnes, James D., Manual of Recommended Practice for Ventilation in Food Service Establishments, National Environmental Health Association.
- Birchfield, John C., Design and Layout of Foodservice Facilities, New York, NY: Van Nostrand Reinhold, 1984.
- Food and Drug Administration, Food Code 1999, National Technical Information Service, Springfield, VA.
- Kazarian, Edward A., Foodservice Facilities Planning, Third Edition, Copyright Van Nostrand-Reinhold, New York, 1989.
- NAFEM, National Association of Food Equipment Manufacturers, Introduction to the Food Service Industry (Kitchen Design).
- North American Association of Food Equipment Manufacturers, An Introduction to the Foodservice Industry, First Edition, 1996.
- Salvato, J. A., Environmental Engineering & Sanitation, Fourth Edition, Copyright John Wiley & Sons, Inc., United States and Canada, 1992.
- Scriveren, Carl and James Stevens, Food Equipment Facts, Troy, NY: Conceptual Design, 1980 or latest printing (or equal publication).
- Stipanuk, David M. and Roffman, Harold Hospitality Facilities Management and Design, American Hotel & Motel Association, Educational Institute, 1992.



**SECTION IV PLAN REVIEW OUTLINE  
WITH HIGHLIGHTS FROM THE 1999  
FOOD CODE**

## **FOOD CODE APPLICABILITY**

(Sections of chapters 8 and 6, subparts of chapters 6 and 5, and parts of chapter 4)

### **A. ADMINISTRATIVE CONSIDERATIONS**

#### **Plan Submission and Approval**

- 8-201.11 When Plans Are Required.
- 8-201.12 Contents of the Plans and Specifications.
- 8-201.13 When a HACCP Plan is Required.
- 8-201.14 Contents of a HACCP Plan.
- 8-203 Construction Inspection and Approval

### **B. PHYSICAL FACILITIES**

#### **Materials for Construction and Repair**

- 6-101.11 Surface Characteristics. (Indoor Areas)
- 6-102.11 Surface Characteristics. (Outdoor Areas)

#### **Design, Construction, and Installation (Cleanability)**

- 6-201.11 Floors, Walls, and Ceilings.
- 6-201.12 Floors, Walls, and Ceilings, Utility Lines.
- 6-201.13 Floor and Wall Junctures, Coved, and Enclosed or Sealed.
- 6-201.14 Floor Carpeting, Restrictions and Installation.
- 6-201.15 Floor Covering, Mats and Duckboards.
- 6-201.16 Wall and Ceiling Coverings and Coatings.
- 6-201.17 Walls and Ceilings, Attachments.
- 6-201.18 Walls and Ceilings, Studs, Joists and Rafters.

#### **Design, Construction, and Installation (Functionality)**

- 6-202.11 Light Bulbs, Protective Shielding.
- 6-202.12 Heating, Ventilating, Air Conditioning System Vents.
- 6-202.13 Insect Control Devices, Design and Installation.
- 6-202.14 Toilet Rooms, Enclosed.
- 6-202.15 Outer Openings, Protected.
- 6-202.16 Exterior Walls and Roofs, Protective Barrier.
- 6-202.17 Outdoor Food Vending Areas, Overhead Protection.
- 6-202.18 Outdoor Servicing Areas, Overhead Protection.
- 6-202.19 Outdoor Walking and Driving Surfaces, Graded to Drain.
- 6-202.110 Outdoor Refuse Areas, Curbed and Graded to Drain.
- 6-202.111 Private Homes and Living or Sleeping Quarters, Use Prohibition.
- 6-202.112 Living or Sleeping Quarters, Separation.

## Numbers and Capacities

6-301	Handwashing Facilities.
6-302	Toilets and Urinals.
6-303	Lighting.
6-304	Ventilation.
6-305	Dressing Areas and Lockers.
6-306	Service Sinks.

## Location and Placement

6-401	Handwashing Facilities.
6-402	Toilet Rooms.
6-403	Employee Accommodations.
6-404	Distressed Merchandise.
6-405	Refuse, Recyclables, and Returnables.

## C. WATER, PLUMBING, AND WASTE

### Water

5-101	Source.
5-102	Quality.
5-103	Quantity and Availability.
5-104	Distribution, Delivery, and Retention.

### Plumbing System

5-201	Materials.
5-202	Design, Construction, and Installation.
5-203	Numbers and Capacities.
5-204	Location and Placement.
5-205	Operation and Maintenance

### Mobile Water Tank and Mobile Food Establishment Water Tank

5-301	Materials.
5-302	Design and Construction.
5-303	Numbers and Capacities.
5-304	Operation and Maintenance

### Sewage, Other Liquid Waste, and Rainwater

5-401	Mobile Holding Tank.
5-402	Retention, Drainage, and Delivery.
5-403	Disposal Facility.

### Refuse, Recyclables, and Returnables

5-501	Facilities on the Premises.
5-502	Removal.

5-503 Facilities for Disposal and Recycling.

#### D. EQUIPMENT, UTENSILS, AND LINENS

##### Applicable Parts of Food Code Chapter 4

- 4-1 Materials for Construction and Repair.
- 4-2 Design and Construction.
- 4-3 Numbers and Capacities.
- 4-4 Location and Installation.
- 4-5 Maintenance and Operation
- 4-6 Cleaning of Equipment and Utensils
- 4-7 Sanitization of Equipment and Utensils
- 4-8 Laundering
- 4-9 Protection of Clean Items